



HT32F12345

Datasheet

**32-Bit Arm® Cortex®-M3 Microcontroller,
up to 64 KB Flash and 16 KB SRAM with 1 MSPS ADC,
USART, UART, SPI, I²C, I²S, MCTM, GPTM, BFTM,
PDMA, CRC, RTC, WDT, EBI, SDIO and USB2.0 FS**

Revision: V1.40 Date: August 03, 2020

Table of Contents

1	General Description	6
2	Features	7
	Core	7
	On-chip Memory	7
	Flash Memory Controller – FMC	7
	Reset Control Unit – RSTCU	8
	Clock Control Unit – CKCU	8
	Power Management – PWRCU	8
	External Interrupt/Event Controller – EXTI	9
	Analog to Digital Converter – ADC	9
	Analog Comparator – CMP	9
	I/O Ports – GPIO	10
	Motor Control Timer – MCTM	10
	General-Purpose Timer – GPTM	11
	Basic Function Timer – BFTM	11
	Watchdog Timer – WDT	11
	Real Time Clock – RTC	12
	Inter-integrated Circuit – I ² C	12
	Serial Peripheral Interface – SPI	12
	Universal Synchronous Asynchronous Receiver Transmitter – USART	13
	Universal Asynchronous Receiver Transmitter – UART	13
	Inter-IC Sound – I ² S	14
	Cyclic Redundancy Check – CRC	14
	Peripheral Direct Memory Access – PDMA	15
	External Bus Interface – EBI	15
	Universal Serial Bus Device Controller – USB	16
	Secure Digital Input Output – SDIO	16
	Debug Support	16
	Package and Operation Temperature	16
3	Overview	17
	Device Information	17
	Block Diagram	18
	Memory Map	19
	Clock Structure	22
4	Pin Assignment	23

5 Electrical Characteristics	30
Absolute Maximum Ratings	30
Recommended DC Operating Conditions	30
On-Chip LDO Voltage Regulator Characteristics.....	30
Power Consumption	31
Reset and Supply Monitor Characteristics.....	32
External Clock Characteristics	33
Internal Clock Characteristics	34
PLL Characteristics	35
USB PLL Characteristics	35
Memory Characteristics	35
I/O Port Characteristics.....	35
ADC Characteristics	37
Comparator Characteristics	39
GPTM/MCTM Characteristics	40
I ² C Characteristics	40
SPI Characteristics	41
I ² S Characteristics	43
SDIO Characteristics	45
USB Characteristics.....	46
6 Package Information	48
SAW Type 46-pin QFN (6.5mm×4.5mm×0.75mm) Outline Dimensions.....	49
48-pin LQFP (7mm×7mm) Outline Dimensions.....	50
64-pin LQFP (7mm×7mm) Outline Dimensions.....	51

List of Tables

Table 1. Features and Peripheral List	17
Table 2. Register Map	20
Table 3. Series Pin Assignment for 46-pin QFN, 48/64-pin LQFP Package	26
Table 4. Pin Description	28
Table 5. Absolute Maximum Ratings	30
Table 6. Recommended DC Operating Conditions	30
Table 7. LDO Characteristics	30
Table 8. Power Consumption Characteristics	31
Table 9. V _{DD} Power Reset Characteristics	32
Table 10. LVD/BOD Characteristics	32
Table 11. High Speed External Clock (HSE) Characteristics	33
Table 12. Low Speed External Clock (LSE) Characteristics	33
Table 13. High Speed Internal Clock (HSI) Characteristics	34
Table 14. Low Speed Internal Clock (LSI) Characteristics	34
Table 15. PLL Characteristics	35
Table 16. USB PLL Characteristics	35
Table 17. Flash Memory Characteristics	35
Table 18. I/O Port Characteristics	35
Table 19. ADC Characteristics	37
Table 20. Comparator Characteristics	39
Table 21. GPTM/MCTM Characteristics	40
Table 22. I ² C Characteristics	40
Table 23. SPI Characteristics	41
Table 24. I ² S Characteristics	43
Table 25. SDIO Characteristics	45
Table 26. USB DC Electrical Characteristics	46
Table 27. USB AC Electrical Characteristics	47

List of Figures

Figure 1. Block Diagram	18
Figure 2. Memory Map.....	19
Figure 3. Clock Structure	22
Figure 4. 46-pin QFN Pin Assignment	23
Figure 5. 48-pin LQFP Pin Assignment.....	24
Figure 6. 64-pin LQFP Assignment.....	25
Figure 7. Figure 7 ADC Sampling Network Model.....	38
Figure 8. I ² C Timing Diagrams.....	40
Figure 9. SPI Timing Diagrams – SPI Master Mode	42
Figure 10. SPI Timing Diagrams - SPI Slave Mode with CPHA = 1.....	43
Figure 11. Timing of I ² S Master Mode.....	44
Figure 12. Timing of I ² S Slave Mode	44
Figure 13. SDIO Default Mode	45
Figure 14. SDIO High-speed Mode	46
Figure 15. USB Signal Rise Time and Fall Time and Cross-Point Voltage (V_{CRS}) Definition	47

1 General Description

The HOLTEK HT32F12345 device is a high performance, low power consumption 32-bit microcontroller based around an Arm® Cortex®-M3 processor core. The Cortex®-M3 is a next-generation processor core which is tightly coupled with Nested Vectored Interrupt Controller (NVIC), SysTick timer, and includes advanced debug support.

The device operates at a frequency of up to 96 MHz with a Flash accelerator to obtain maximum efficiency. It provides 64 KB of embedded Flash memory for code/data storage and 16 KB of embedded SRAM memory for system operation and application program usage. A variety of peripherals, such as ADC, I²C, USART, UART, SPI, I²S, PDMA, GPTM, MCTM, EBI, CRC-16/32, SDIO, USB2.0 FS and SW-DP (Serial Wire Debug Port), etc., are also implemented in the device. Several power saving modes provide the flexibility for maximum optimization between wakeup latency and power consumption, an especially important consideration in low power applications.

The above features ensure that the device is suitable for use in a wide range of applications, especially in areas such as white goods application control, power monitors, alarm systems, consumer products, handheld equipment, data logging applications, motor control, fingerprint recognition and so on.

arm CORTEX

2 Features

Core

- 32-bit Arm® Cortex®-M3 processor core
- Up to 96 MHz operating frequency
- Single-cycle multiplication and hardware division
- Integrated Nested Vectored Interrupt Controller (NVIC)
- 24-bit SysTick timer

The Cortex®-M3 processor is a general-purpose 32-bit processor core especially suitable for products requiring high performance and low power consumption microcontrollers. It offers many special features such as a Thumb-2 instruction set, hardware divider, low latency interrupt respond time, atomic bit-banding access and multiple buses for simultaneous accesses. The Cortex®-M3 processor is based on the ARMv7 architecture and supports both Thumb and Thumb-2 instruction sets.

On-chip Memory

- 64 KB on-chip Flash memory for instruction/data and option storage
- 16 KB on-chip SRAM
- Supports multiple boot modes

The Arm® Cortex®-M3 processor is structured using Harvard architecture which uses a separate bus structure to fetch instructions and load/store data. The instruction code and data are both located in the same memory address space but in different address ranges. The maximum address range of the Cortex®-M3 is 4 GB due to its 32-bit bus address width. Additionally, a pre-defined memory map is provided by the Cortex®-M3 processor to reduce the software complexity of repeated implementation for different device vendors. However, some regions are used by the Arm® Cortex®-M3 system peripherals. Refer to the Arm® Cortex®-M3 Technical Reference Manual for more information. Figure 2 shows the memory map of the HT32F12345 device, including Code, SRAM, peripheral, and other pre-defined regions.

Flash Memory Controller – FMC

- Flash accelerator for maximum efficiency
- 32-bit word programming with In System Programming Interface (ISP) and In Application Programming (IAP)
- Flash protection capability to prevent illegal access

The Flash Memory Controller, FMC, provides all the necessary functions and pre-fetch buffer for the embedded on-chip Flash Memory. Since the access speed of the Flash Memory is slower than the CPU, a wide access interface with a pre-fetch buffer and cache are provided for the Flash Memory in order to reduce the CPU waiting time which will cause CPU instruction execution delays. Flash Memory word program/page erase functions are also provided.

Reset Control Unit – RSTCU

- Supply supervisor:
 - Power On Reset / Power Down Reset – POR/PDR
 - Brown-out Detector – BOD
 - Programmable Low Voltage Detector – LVD

The Reset Control Unit, RSTCU, has three kinds of reset, a power on reset, a system reset and an APB unit reset. The power on reset, known as a cold reset, resets the full system during power up. A system reset resets the processor core and peripheral IP components with the exception of the SW-DP controller. The resets can be triggered by an external signal, internal events and the reset generators.

Clock Control Unit – CKCU

- External 4 to 16 MHz crystal oscillator
- External 32.768 kHz crystal oscillator
- Internal 8 MHz RC oscillator trimmed to ± 2 % accuracy at 3.3 V operating voltage and 25 °C operating temperature
- Internal 32 kHz RC oscillator
- Integrated system clock PLL
- Independent clock divider and gating bits for peripheral clock sources

The Clock Control unit, CKCU, provides a range of oscillator and clock functions. These include a High Speed Internal RC oscillator (HSI), a High Speed External crystal oscillator (HSE), a Low Speed Internal RC oscillator (LSI), a Low Speed External crystal oscillator (LSE), a Phase Lock Loop (PLL), a HSE clock monitor, clock prescalers, clock multiplexers, APB clock divider and gating circuitry. The clocks of the AHB, APB and Cortex®-M3 are derived from the system clock (CK_SYS) which can come from the LSI, LSE, HSI, HSE or PLL. The Watchdog Timer and Real Time Clock (RTC) use either the LSI or LSE as their clock source. The maximum operating frequency of the system core clock (CK_AHB) can be up to 96 MHz.

Power Management – PWRCU

- Single V_{DD} power supply: 2.0 V to 3.6 V
- Integrated 1.5V LDO regulator for CPU core, peripherals and memories power supply
- V_{BAT} battery power supply for RTC and backup registers
- Three power domains: V_{DD} , 1.5 V and Backup
- Four power saving modes: Sleep, Deep-Sleep1, Deep-Sleep2, Power-Down

Power consumption can be regarded as one of the most important issues for many embedded system applications. Accordingly the Power Control Unit, PWRCU, in the device provides many types of power saving modes such as Sleep, Deep-Sleep1, Deep-Sleep2 and Power-Down mode. These operating modes reduce the power consumption and allow the application to achieve the best trade-off between the conflicting demands of CPU operating time, speed and power consumption.

External Interrupt/Event Controller – EXTI

- Up to 16 EXTI lines with configurable trigger source and type
- All GPIO pins can be selected as EXTI trigger source
- Source trigger type includes high level, low level, negative edge, positive edge, or both edge
- Individual interrupt enable, wakeup enable and status bits for each EXTI line
- Software interrupt trigger mode for each EXTI line
- Integrated deglitch filter for short pulse blocking

The External Interrupt/Event Controller, EXTI, comprises 16 edge detectors which can generate a wake-up event or interrupt requests independently. Each EXTI line can also be masked independently.

Analog to Digital Converter – ADC

- 12-bit SAR ADC engine
- Up to 1 Msps conversion rate
- Up to 12 external analog input channels
- External reference voltage input possibility

A 12-bit multi-channel ADC is integrated in the device. There are multiplexed channels, which include 12 external analog signal channels and 2 internal channels can be measured. If the input voltage is required to remain within a specific threshold window, an Analog Watchdog function will monitor and detect these signals. An interrupt will then be generated to inform the device that the input voltage is not within the preset threshold levels. There are three conversion modes to convert an analog signal to digital data. The ADC can be operated in one shot, continuous and discontinuous conversion modes.

Analog Comparator – CMP

- Two rail-to-rail comparators
- Each comparator has configurable negative inputs used for flexible voltage selection
- Dedicated I/O pin or internal voltage reference provided by 6-bit scaler
- Programmable hysteresis
- Programming speed and consumption
- Comparator output can be output to I/O or to timers or ADC trigger inputs
- 6-bit scaler can be configurable to dedicated I/O for voltage reference
- Comparator has interrupt generation capability with wakeup MCU from Sleep or Deep Sleep modes through the EXTI controller

The two general purpose comparators (CMP) are implemented within the device. They can be configured either as standalone comparators or combined with the different kinds of peripheral IP. Each comparator is capable of asserting interrupts to the NVIC or wakeup the MCU Sleep or Deep Sleep modes through EXTI wakeup event management unit.

I/O Ports – GPIO

- Up to 51 GPIOs
- Port A, B, C, D are mapped as 16 external interrupts – EXTI
- Almost I/O pins are configurable output driving current

There are up to 51 General Purpose I/O pins, GPIO, named from PA0 ~ PA15 to PD0 ~ PD2 for the implementation of logic input/output functions. Each of the GPIO ports has a series of related control and configuration registers to maximize flexibility and to meet the requirements of a wide range of applications.

The GPIO ports are pin-shared with other alternative functions to obtain maximum functional flexibility on the package pins. The GPIO pins can be used as alternative functional pins by configuring the corresponding registers regardless of the input or output pins.

The external interrupts on the GPIO pins of the device have related control and configuration registers in the External Interrupt Control Unit, EXTI.

Motor Control Timer – MCTM

- One 16-bit up, down, up/down auto-reload counters
- 16-bit programmable prescaler allowing division of the counter clock frequency by any factor between 1 and 65536
- Input Capture function
- Compare Match Output
- PWM waveform generation with edge aligned and center-aligned Counting Modes
- Single Pulse Mode Output
- Complementary Outputs with programmable dead-time insertion
- Encoder interface controller with two inputs using quadrature decoder
- Supports 3-phase motor control and hall sensor interface
- Brake input to force the timer's output signals into a reset or fixed condition

The Motor Control Timer consists of a single 16-bit up/down counter; four 16-bit CCRs (Capture/Compare Registers), single 16-bit counter-reload register (CRR), single 8-bit repetition counter and several control/status registers. It can be used for a variety of purposes including measuring the pulse widths of input signals or generating output waveforms such as compare match outputs, PWM outputs or complementary PWM outputs with dead-time insertion. The MCTM supports an Encoder interface controller to an incremental encoder with two inputs. The MCTM is capable of offering full functional support for motor control, hall sensor interfacing and brake input.

General-Purpose Timer – GPTM

- One 16-bit up, down, up/down auto-reload counters
- 16-bit programmable prescaler allowing dividing the counter clock frequency by any factor between 1 and 65536
- Input Capture function
- Compare Match Output
- PWM waveform generation with Edge-aligned and Center-aligned Counting Modes
- Single Pulse Mode Output
- Encoder interface controller with two inputs using quadrature decoder

The General Purpose Timer consists of one 16-bit up/down-counter, four 16-bit Capture/Compare Registers (CCRs), one 16-bit Counter Reload Register (CRR) and several control/status registers. They can be used for a variety of purposes including general time measurement, input signal pulse width measurement, output waveform generation such as single pulse generation, or PWM output generation. The GPTM supports an Encoder Interface using a decoder with two inputs.

Basic Function Timer – BFTM

- One 32-bit compare/match count-up counters - no I/O control features
- One shot mode - counting stops after a match condition
- Repetitive mode - restart counter after a match condition

The Basic Function Timer is a simple count-up 32-bit counter designed to measure time intervals and generate a one shot or repetitive interrupts. The BFTM operates in two functional modes, repetitive or one shot mode. In the repetitive mode the BFTM restarts the counter when a compare match event occurs. The BFTM also supports a one shot mode which forces the counter to stop counting when a compare match event occurs.

Watchdog Timer – WDT

- 12-bit down counter with 3-bit prescaler
- Interrupt or reset event for the system
- Programmable watchdog timer window function
- Register write protection function

The Watchdog Timer is a hardware timing circuit that can be used to detect system failures due to software malfunctions. It includes a 12-bit count-down counter, a prescaler, a WDT counter value register, a WDT delta value register, interrupt related circuits, WDT operation control circuitry and a WDT protection mechanism. The Watchdog Timer can be operated in an interrupt mode or a reset mode. The Watchdog Timer will generate an interrupt or a reset when the counter counts down and reaches a zero value. If the software does not reload the counter value before a Watchdog Timer underflow occurs, an interrupt or a reset will be generated when the counter underflows. In addition, an interrupt or reset is also generated if the software reloads the counter when the counter value is greater than or equal to the WDT delta value. This means the counter must be reloaded within a limited timing window using a specific method. The Watchdog Timer counter can be stopped while the processor is in the debug mode. There is a register write protect function which can be enabled to prevent it from changing the Watchdog Timer configuration unexpectedly.

Real Time Clock – RTC

- 32-bit up-counter with a programmable prescaler
- Alarm function
- Interrupt and Wake-up event

The Real Time Clock, RTC for short, includes an APB interface, a 32-bit count-up counter, a control register, a prescaler, a compare register and a status register. Most of the RTC circuits are located in the Backup Domain except for the APB interface. The APB interface is located in the V_{DD15} power domain. Therefore, it is necessary to be isolated from the ISO signal that comes from the power control unit when the V_{DD15} power domain is powered off, that is when the device enters the Power-Down mode. The RTC counter is used as a wakeup timer to generate a system resume signal from the Power-Down mode.

Inter-integrated Circuit – I²C

- Supports both master and slave modes with a frequency of up to 1 MHz
- Provide an arbitration function and clock synchronization
- Supports 7-bit and 10-bit addressing modes and general call addressing
- Supports slave multi-addressing mode with maskable address

The I²C Module is an internal circuit allowing communication with an external I²C interface which is an industry standard two line serial interface used for connection to external hardware. These two serial lines are known as a serial data line, SDA, and a serial clock line, SCL. The I²C module provides three data transfer rates: (1) 100 kHz in the Standard mode, (2) 400 kHz in the Fast mode and (3) 1 MHz in the Fast mode plus mode. The SCL period generation register is used to setup different kinds of duty cycle implementations for the SCL pulse.

The SDA line which is connected directly to the I²C bus is a bi-directional data line between the master and slave devices and is used for data transmission and reception. The I²C module also has an arbitration detect function and clock synchronization to prevent situations where more than one master attempts to transmit data to the I²C bus at the same time.

Serial Peripheral Interface – SPI

- Supports both master and slave mode
- Frequency of up to ($f_{PCLK}/2$) MHz for master mode and ($f_{PCLK}/3$) MHz for slave mode
- FIFO Depth: 8 levels
- Multi-master and multi-slave operation

The Serial Peripheral Interface, SPI, provides an SPI protocol data transmit and receive function in both master and slave modes. The SPI interface uses 4 pins, which are the serial data input and output lines, MISO and MOSI, the clock line, SCK, and the slave select line, SEL. One SPI device acts as a master device which controls the data flow using the SEL and SCK signals to indicate the start of data communication and the data sampling rate. To receive a data byte, the streamed data bits are latched on a specific clock edge and stored in the data register or in the RX FIFO. Data transmission is carried out in a similar way but in a reverse sequence. The mode fault detection provides a capability for multi-master applications.

Universal Synchronous Asynchronous Receiver Transmitter – USART

- Supports both asynchronous and clocked synchronous serial communication modes
- Asynchronous operating baud rate up to ($f_{\text{PCLK}}/16$) MHz and synchronous operating rate up to ($f_{\text{PCLK}}/8$) MHz
- Full duplex communication
- Fully programmable serial communication characteristics including:
 - Word length: 7, 8, or 9-bit character
 - Parity: Even, odd, or no-parity bit generation and detection
 - Stop bit: 1 or 2 stop bit generation
 - Bit order: LSB-first or MSB-first transfer
- Error detection: Parity, overrun, and frame error
- Auto hardware flow control mode – RTS, CTS
- IrDA SIR encoder and decoder
- RS485 mode with output enable control
- FIFO Depth: 8-level for both receiver and transmitter

The Universal Synchronous Asynchronous Receiver Transceiver, USART, provides a flexible full duplex data exchange using synchronous or asynchronous transfer. The USART is used to translate data between parallel and serial interfaces, and is commonly used for RS232 standard communication. The USART peripheral function supports four types of interrupt including Line Status Interrupt, Transmitter FIFO Empty Interrupt, Receiver Threshold Level Reaching Interrupt and Time Out Interrupt. The USART module includes a transmitter FIFO, (TX_FIFO) and a receiver FIFO (RX_FIFO). The software can detect a USART error status by reading the Line Status Register, LSR. The status includes the type and the condition of transfer operations as well as several error conditions resulting from Parity, Overrun, Framing and Break events.

Universal Asynchronous Receiver Transmitter – UART

- Asynchronous serial communication operating baud-rate up to ($f_{\text{PCLK}}/16$) MHz
- Full duplex communication
- Fully programmable serial communication characteristics including:
 - Word length: 7, 8 or 9-bit character
 - Parity: Even, odd or no-parity bit generation and detection
 - Stop bit: 1 or 2 stop bit generation
 - Bit order: LSB-first or MSB-first transfer
- Error detection: Parity, overrun and frame error

The Universal Asynchronous Receiver Transceiver, UART, provides a flexible full duplex data exchange using asynchronous transfer. The UART is used to translate data between parallel and serial interfaces, and is commonly used for RS232 standard communication. The UART peripheral function supports Line Status Interrupt. The software can detect a UART error status by reading the Line Status Register, LSR. The status includes the type and the condition of transfer operations as well as several error conditions resulting from Parity, Overrun, Framing and Break events.

Inter-IC Sound – I²S

- Master or slave mode
- Mono and stereo
- I2S-justified, Left-justified, and Right-justified mode
- 8/16/24/32-bit sample size with 32-bit channel extended
- 8 × 32-bits Tx & Rx FIFO with PDMA supported
- 8-bit Fractional Clock Divider with rate control

The I²S is a synchronous communication interface that can be used as a master or slave to exchange data with other audio peripherals, such as ADCs or DACs. The I²S supports a variety of data formats. In addition to the stereo I2S-justified, Left-justified and Right-justified modes, there are mono PCM modes with 8/16/24/32-bit sample size. When the I²S operates in the master mode, then when using the fractional divider, it can provide an accurate sampling frequency output and support the rate control function and fine-tuning of the output frequency to avoid system problems caused by the cumulative frequency error between different devices.

Cyclic Redundancy Check – CRC

- Supports CRC16 polynomial: 0x8005,
 $X^{16}+X^{15}+X^2+1$
- Supports CCITT CRC16 polynomial: 0x1021,
 $X^{16}+X^{12}+X^5+1$
- Supports IEEE-802.3 CRC32 polynomial: 0x04C11DB7,
 $X^{32}+X^{26}+X^{23}+X^{22}+X^{16}+X^{12}+X^{11}+X^{10}+X^8+X^7+X^5+X^4+X^2+X+1$
- Supports 1's complement, byte reverse & bit reverse operation on data and checksum
- Supports byte, half-word & word data size
- Programmable CRC initial seed value
- CRC computation executed in 1 AHB clock cycle for 8-bit data and 4 AHB clock cycles for 32-bit data
- Supports PDMA to complete a CRC computation of a block of memory

The CRC calculation unit is an error detection technique test algorithm which is used to verify data transmission or storage data correctness. A CRC calculation takes a data stream or a block of data as input and generates a 16-bit or 32-bit output remainder. Ordinarily, a data stream is suffixed by a CRC code and used as a checksum when being sent or stored. Therefore, the received or restored data stream is calculated by the same generator polynomial as described above. If the new CRC code result does not match the one calculated earlier, that means data stream contains a data error.

Peripheral Direct Memory Access – PDMA

- 12 channels with trigger source grouping
- 8/16/32-bit width data transfer
- Supports Address increment, decrement or fixed mode
- 4-level programmable channel priority
- Auto reload mode
- Supports trigger source:
 - ADC, SPI, EBI, CRC, USART, UART, I²C, I²S, GPTM, MCTM, SDIO and software request

The Peripheral Direct Memory Access controller, PDMA, moves data between the peripherals and the system memory on the AHB bus. Each PDMA channel has a source address, destination address, block length and transfer count. The PDMA can exclude the CPU intervention and avoid interrupt service routine execution. It improves system performance as the software does not need to join each data movement operation.

External Bus Interface – EBI

- Programmable interface for various memory types
- Translate the AHB transactions into the appropriate external device protocol
- Memory bank regions and independent chip select control for each memory bank
- Programmable timings to support a wide range of devices
- Includes page read mode
- Automatic translation when the AHB transaction width and external memory interface width is different
- Write buffer to decrease the stalling of the AHB write burst transaction
- Multiplexed and non-multiplexed address and data line configurations
 - Up to 21 address lines
 - Up to 16-bit data bus width

The external bus interface is able to access external parallel interface devices such as SRAM, Flash and LCD modules. The interface is memory mapped into the internal address map of the CPU. The data and address lines are multiplexed in order to reduce the number of pins required to connect to the external devices. The read/write timing of the bus can be adjusted to meet the timing specification of the external devices. Note the interface only supports asynchronous 8-bit or 16-bit bus interface.

Universal Serial Bus Device Controller – USB

- Complies with USB 2.0 full-speed (12 Mbps) specification
- On-chip USB full-speed transceiver
- 1 control endpoint (EP0) for control transfer
- 3 single-buffered endpoints for bulk and interrupt transfer
- 4 double-buffered endpoints for bulk, interrupt and isochronous transfer
- 1024-byte EP-SRAM used as the endpoint data buffers

The USB device controller is compliant with the USB 2.0 full-speed specification. There is one control endpoint known as Endpoint 0 and seven configurable endpoints. A 1024-byte SRAM is used as the endpoint buffer. Each endpoint buffer size is programmable using corresponding registers, which provides maximum flexibility for various applications. The integrated USB full-speed transceiver helps to minimize the overall system complexity and cost. The USB functional block also contains the resume and suspend feature to meet the requirements of low-power consumption.

Secure Digital Input Output – SDIO

- Supports two different data bus modes: 1-bit (default) and 4-bit
- Supports two different speed modes: Normal speed (default) and High speed
- SD clock frequency of up to 48 MHz
- SPI mode and MMC stream mode not supported

The SDIO includes a command register, argument register, response registers, data buffer, timeout counter and error detection logic. The SDIO supports single block and multi-block data transfers and is compatible with the PDMA, minimizing processor intervention for large data transfers.

Debug Support

- Serial Wire Debug Port SW-DP
- 6 instruction comparators and 2 literal comparators for hardware breakpoint or code / literal patches
- 4 comparators for hardware watchpoints
- 1-bit asynchronous trace for serial wire debug mode – TRACESWO

Package and Operation Temperature

- 46-pin QFN, 48/64-pin LQFP package
- Operation temperature range: -40 °C to 85 °C

3 Overview

Device Information

Table 1. Features and Peripheral List

Peripherals		HT32F12345
Main Flash (KB)		63
Option Bytes Flash (KB)		1
SRAM (KB)		16
Timers	MCTM	2
	GPTM	2
	BFTM	2
	RTC	1
	WDT	1
Communication	USB	1
	USART	2
	UART	2
	SPI	2
	I ² C	2
	I ² S	1
PDMA		12 channels
SDIO		1
EBI		1
CRC		1
GPIO		Up to 51
EXTI		16
12-bit ADC		1
Number of channels		Max. 12 Channels
Comparator		2
CPU frequency		Up to 96 MHz
Operating voltage		2.0 V ~ 3.6 V
Operating temperature		-40 °C ~ 85 °C
Package		46-pin QFN, 48/64-pin LQFP

Block Diagram

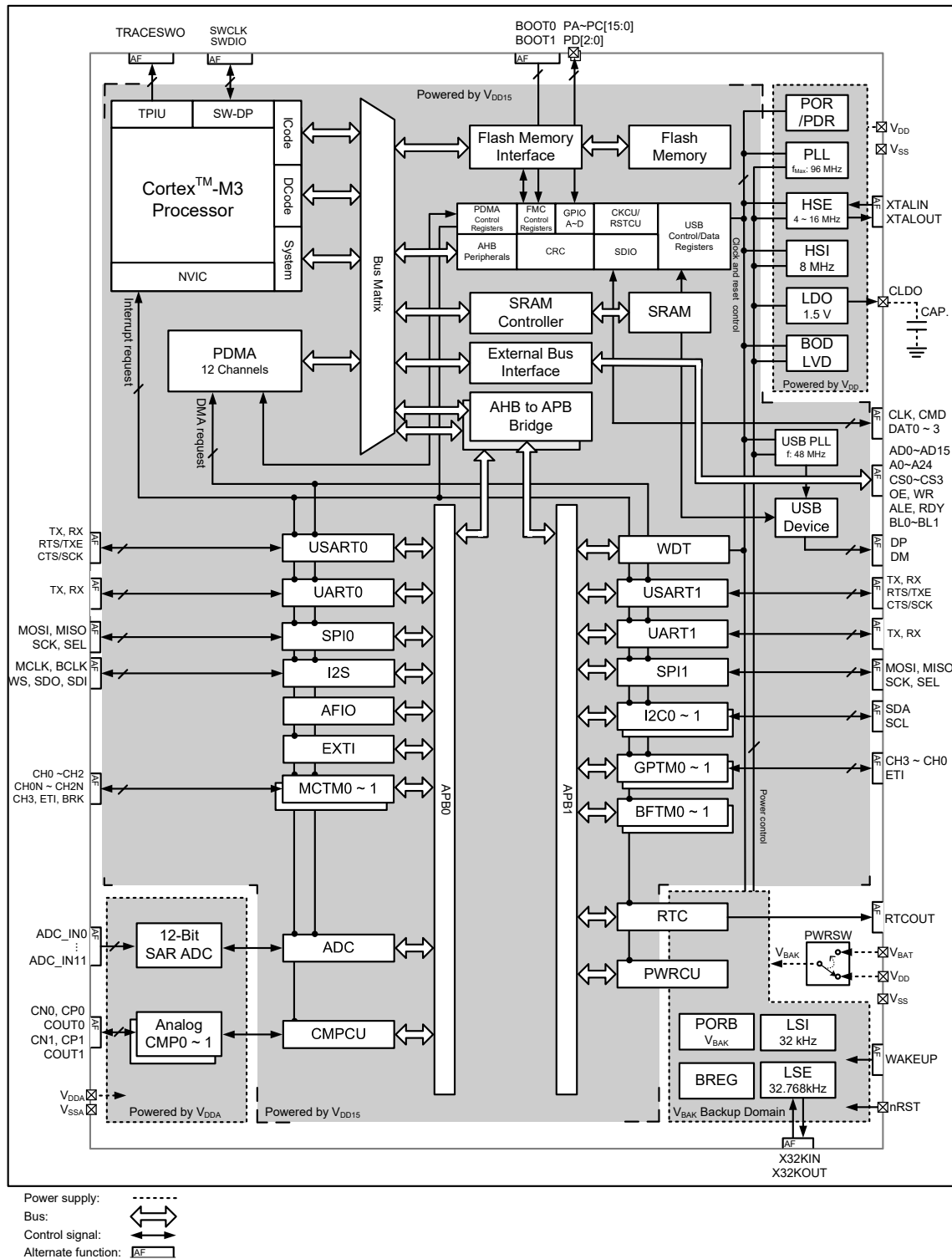

Figure 1. Block Diagram

Memory Map

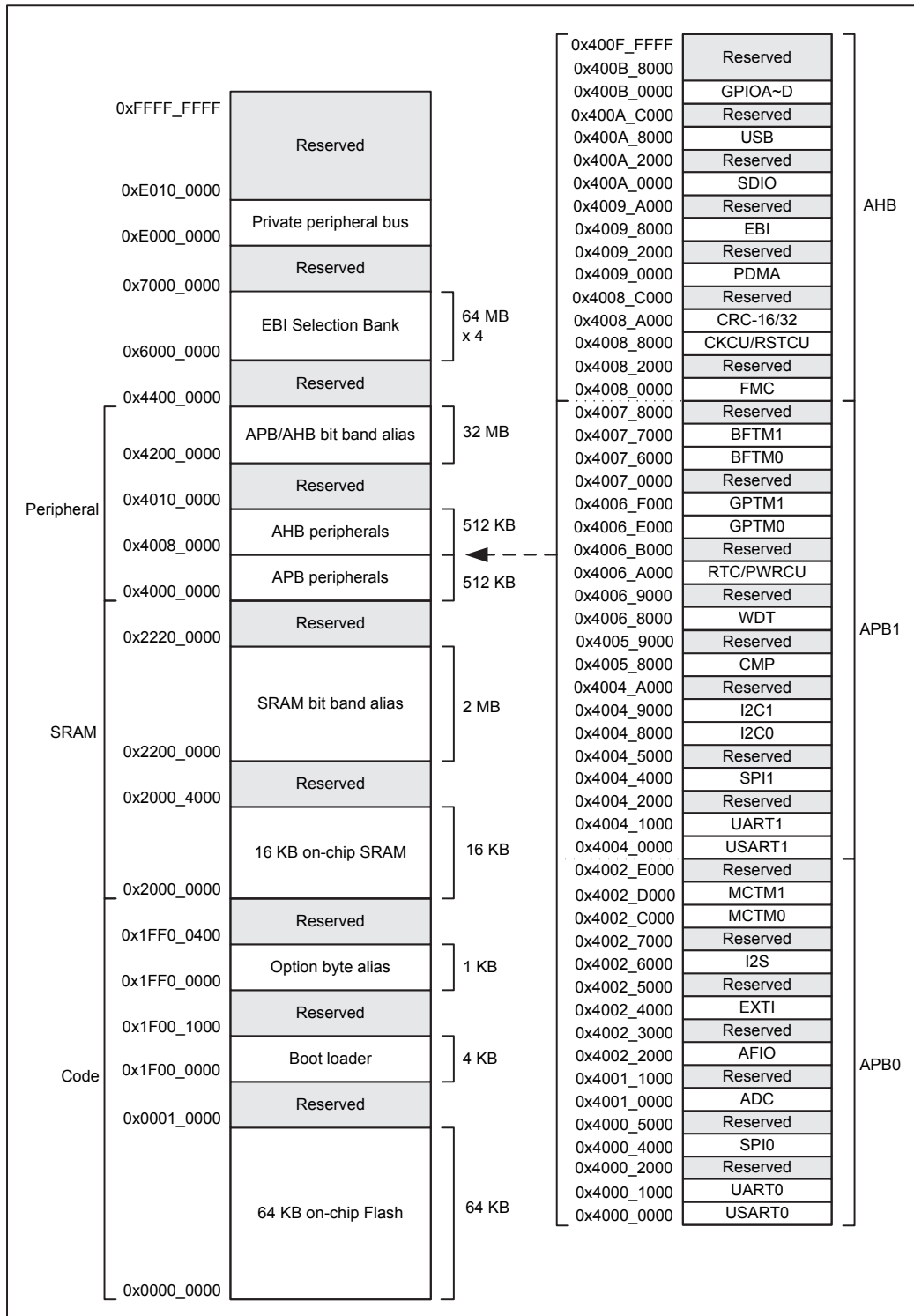

Figure 2. Memory Map

Table 2. Register Map

Start Address	End Address	Peripheral	Bus
0x4000_0000	0x4000_0FFF	USART0	APB0
0x4000_1000	0x4000_1FFF	UART0	
0x4000_2000	0x4000_3FFF	Reserved	
0x4000_4000	0x4000_4FFF	SPI0	
0x4000_5000	0x4000_FFFF	Reserved	
0x4001_0000	0x4001_0FFF	ADC	
0x4001_1000	0x4002_1FFF	Reserved	
0x4002_2000	0x4002_2FFF	AFIO	
0x4002_3000	0x4002_3FFF	Reserved	
0x4002_4000	0x4002_4FFF	EXTI	
0x4002_5000	0x4002_5FFF	Reserved	
0x4002_6000	0x4002_6FFF	I2S	
0x4002_7000	0x4002_BFFF	Reserved	
0x4002_C000	0x4002_CFFF	MCTM0	
0x4002_D000	0x4002_DFFF	MCTM1	
0x4002_E000	0x4003_FFFF	Reserved	
0x4004_0000	0x4004_0FFF	USART1	APB1
0x4004_1000	0x4004_1FFF	UART1	
0x4004_2000	0x4004_3FFF	Reserved	
0x4004_4000	0x4004_4FFF	SPI1	
0x4004_5000	0x4004_7FFF	Reserved	
0x4004_8000	0x4004_8FFF	I2C0	
0x4004_9000	0x4004_9FFF	I2C1	
0x4004_A000	0x4005_7FFF	Reserved	
0x4005_8000	0x4005_8FFF	CMP	
0x4005_9000	0x4006_7FFF	Reserved	
0x4006_8000	0x4006_8FFF	WDT	
0x4006_9000	0x4006_9FFF	Reserved	
0x4006_A000	0x4006_AFFF	RTC/PWRCU	
0x4006_B000	0x4006_DFFF	Reserved	
0x4006_E000	0x4006_EFFF	GPTM0	
0x4006_F000	0x4006_FFFF	GPTM1	
0x4007_0000	0x4007_5FFF	Reserved	
0x4007_6000	0x4007_6FFF	BFTM0	
0x4007_7000	0x4007_7FFF	BFTM1	
0x4007_8000	0x4007_FFFF	Reserved	

Start Address	End Address	Peripheral	Bus
0x4008_0000	0x4008_1FFF	FMC	AHB
0x4008_2000	0x4008_7FFF	Reserved	
0x4008_8000	0x4008_9FFF	CKCU/RSTCU	
0x4008_A000	0x4008_BFFF	CRC-16/32	
0x4008_C000	0x4008_FFFF	Reserved	
0x4009_0000	0x4009_1FFF	PDMA Control Registers	
0x4009_2000	0x4009_7FFF	Reserved	
0x4009_8000	0x4009_9FFF	EBI Control Registers	
0x4009_A000	0x4009_FFFF	Reserved	
0x400A_0000	0x400A_1FFF	SDIO	
0x400A_2000	0x400A_7FFF	Reserved	
0x400A_8000	0x400A_9FFF	USB Control Registers	
0x400A_A000	0x400A_BFFF	USB SRAM	
0x400A_C000	0x400A_FFFF	Reserved	
0x400B_0000	0x400B_1FFF	GPIOA	
0x400B_2000	0x400B_3FFF	GPIOB	
0x400B_4000	0x400B_5FFF	GPIOC	
0x400B_6000	0x400B_7FFF	GPIOD	
0x400B_8000	0x400F_FFFF	Reserved	

Clock Structure

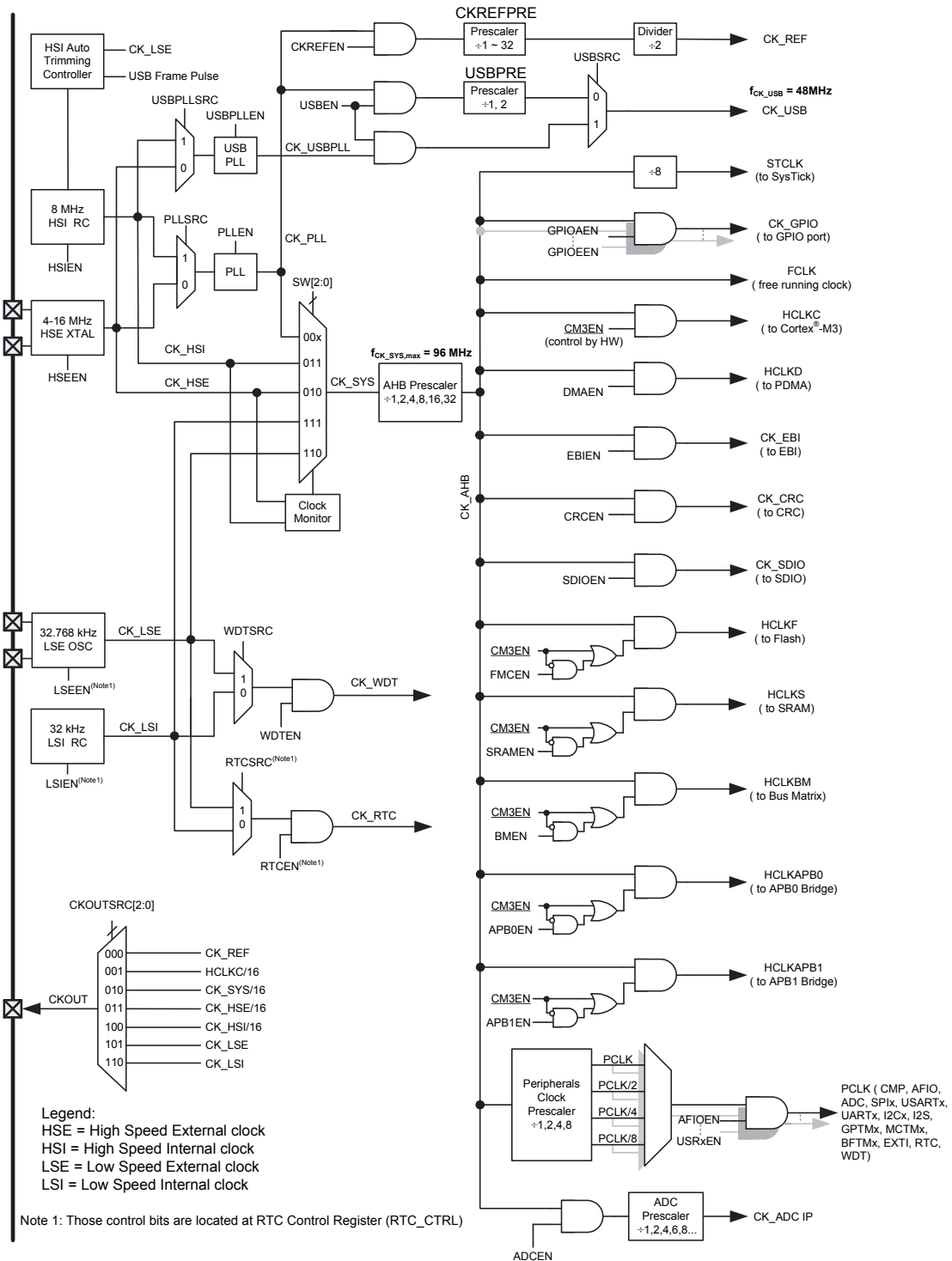
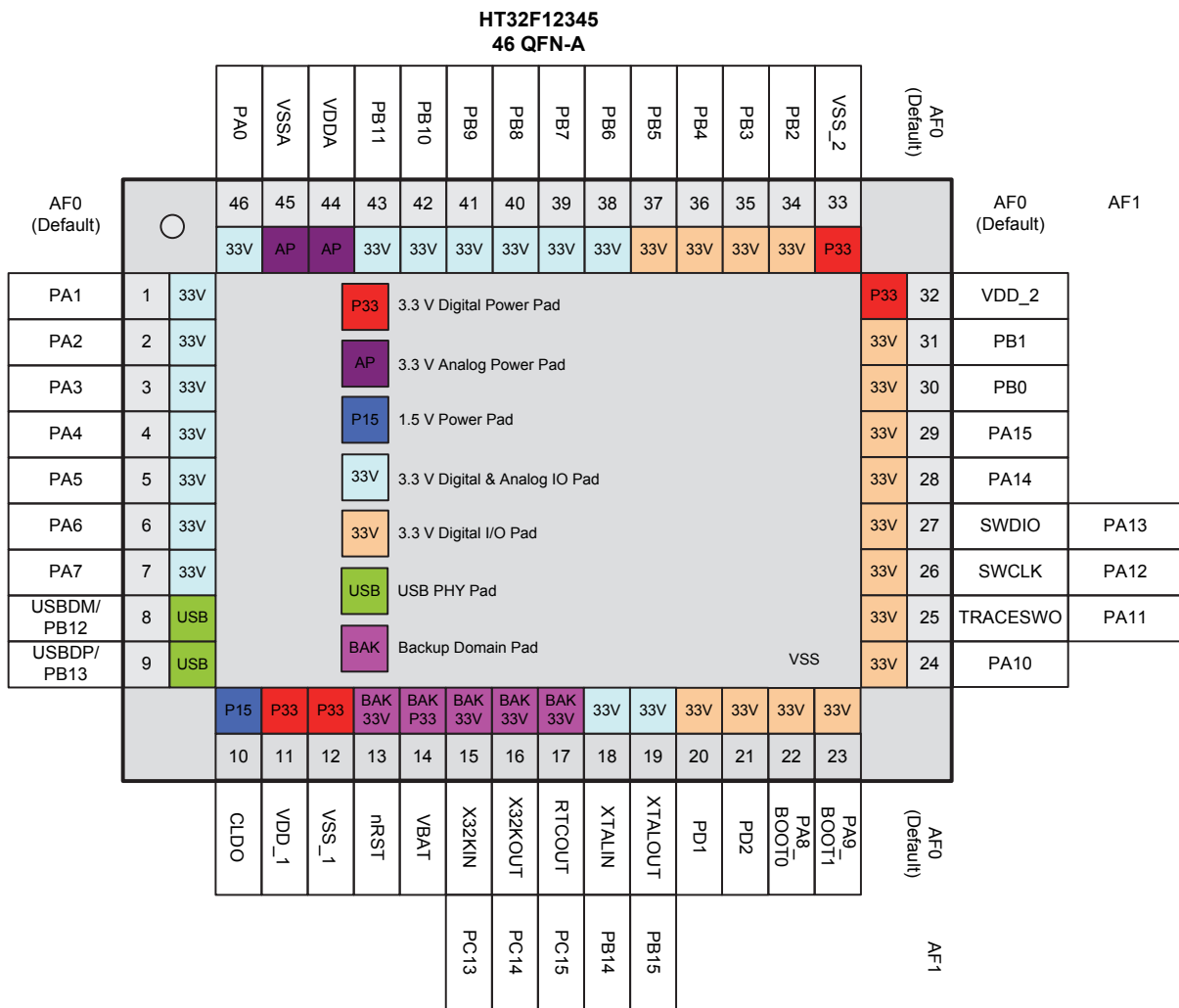

Figure 3. Clock Structure

4 Pin Assignment



4 Pin Assignment

Figure 4. 46-pin QFN Pin Assignment

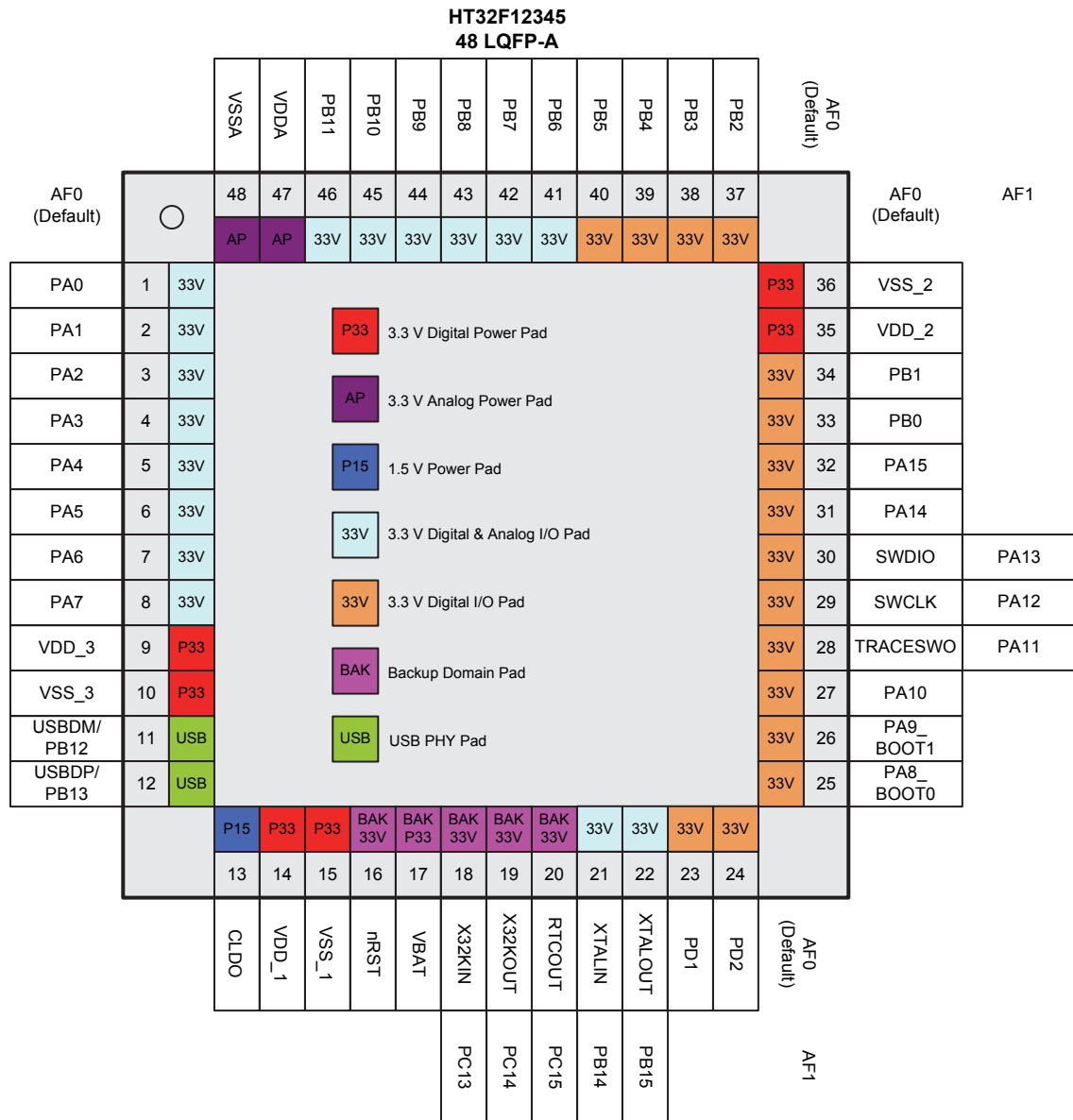

4 Pin Assignment

Figure 5. 48-pin LQFP Pin Assignment

Table 3. Series Pin Assignment for 46-pin QFN, 48/64-pin LQFP Package

Package			Alternate Function Mapping															
64 LQFP	48 LQFP	46 QFN	AF0 System Default	AF1 GPIO	AF2 ADC	AF3 CMP	AF4 MCTM /GPTM	AF5 SPI	AF6 USART /UART	AF7 I ² C	AF8 N/A	AF9 EBI	AF10 I2S	AF11 SDIO	AF12 N/A	AF13 N/A	AF14 N/A	AF15 System Other
1	1	46	PA0		ADC_IN0		GT1_CH0	SPI1_SCK	USR0_RTS	I2C1_SCL			I2S_WS					
2	2	1	PA1		ADC_IN1		GT1_CH1	SPI1_MOSI	USR0_CTS	I2C1_SDA			I2S_BCLK	SD_DAT1				
3	3	2	PA2		ADC_IN2		GT1_CH2	SPI1_MISO	USR0_TX				I2S_SDO	SD_DAT2				
4	4	3	PA3		ADC_IN3		GT1_CH3	SPI1_SEL	USR0_RX				I2S_SDI	SD_DAT3				
5	5	4	PA4		ADC_IN4		GT0_CH0	SPI0_SCK	USR1_TX	I2C0_SCL				SD_CMD				
6	6	5	PA5		ADC_IN5		GT0_CH1	SPI0_MOSI	USR1_RX	I2C0_SDA				SD_CLK				
7	7	6	PA6		ADC_IN6		GT0_CH2	SPI0_MISO	USR1_RTS					SD_DAT0				
8	8	7	PA7		ADC_IN7		GT0_CH3	SPI0_SEL	USR1_CTS				I2S_MCLK					
9	9		VDD_3															
10	10	EP*	VSS_3															
11			PC9		ADC_IN8		GT0_CH0	SPI1_SEL	UR0_TX	I2C1_SCL		EBI_A19		SD_DAT0				
12			PC10		ADC_IN9		GT0_CH1	SPI1_SCK	UR0_RX	I2C1_SDA		EBI_A20		SD_DAT1				
13			PC11		ADC_IN10		GT0_CH2	SPI1_MOSI				EBI_A0		SD_DAT2				
14			PC12		ADC_IN11		GT0_CH3	SPI1_MISO				EBI_A1		SD_DAT3				
15	11	8	PB12				MT1_CH2		USR0_TX	I2C0_SCL								
15	11	8	USBDM															
16	12	9	USBDP															
16	12	9	PB13				MT1_CH2N		USR0_RX	I2C0_SDA								
17	13	10	CLDO															
18	14	11	VDD_1															
19	15	12	VSS_1															
20	16	13	nRST															
21	17	14	VBAT															
22	18	15	X32KIN	PC13														
23	19	16	X32KOUT	PC14														
24	20	17	RTCOUT	PC15														WAKEUP
25			PD0				MT1_ETI			I2C0_SDA		EBI_A18	I2S_SDI	SD_CMD				
26	21	18	XTALIN	PB14														
27	22	19	XTALOUT	PB15														
28	23	20	PD1				MT1_CH0	SPI0_SEL		I2C1_SCL		EBI_A16	I2S_MCLK	SD_CLK				
29	24	21	PD2				MT1_CH0N	SPI0_SCK		I2C1_SDA		EBI_A17		SD_CMD				
30			PC0				GT1_CH0	SPI1_SEL				EBI_AD13	I2S_WS	SD_DAT1				
31			PC1				GT1_CH1	SPI1_SCK				EBI_AD14	I2S_BCLK	SD_DAT2				
32			PC2				GT1_CH2	SPI1_MOSI	UR1_TX	I2C0_SCL		EBI_AD15	I2S_SDO	SD_DAT3				
33			PC3				GT1_CH3	SPI1_MISO	UR1_RX	I2C0_SDA		EBI_CS3	I2S_SDI	SD_DAT0				

Package			Alternate Function Mapping															
64 LQFP	48 LQFP	46 QFN	AF0	AF1	AF2	AF3	AF4	AF5	AF6	AF7	AF8	AF9	AF10	AF11	AF12	AF13	AF14	AF15
			System Default	GPIO	ADC	CMP	MCTM /GPTM	SPI	USART /UART	I ² C	N/A	EBI	I2S	SDIO	N/A	N/A	N/A	System Other
34	25	22	PA8_BOOT0				GT0_ETI		USR0_TX				I2S_MCLK					CKOUT
35	26	23	PA9_BOOT1					SPI0_MOSI				EBI_A1	I2S_WS					
36	27	24	PA10				MT1_CH1		USR0_RX					SD_DAT0				
37	28	25	TRACESWO	PA11			MT1_CH1N	SPI0_MISO				EBI_A0	I2S_MCLK					
38	29	26	SWCLK	PA12														
39	30	27	SWDIO	PA13														
40	31	28	PA14				MT0_CH0	SPI1_SEL	USR1_TX			EBI_AD0						
41	32	29	PA15				MT0_CH0N	SPI1_SCK	USR1_RX			EBI_AD1						
42			VDD_2															
43			VSS_2															
44	33	30	PB0				MT0_CH1	SPI1_MOSI	USR0_TX	I2C0_SCL		EBI_AD2						
45	34	31	PB1				MT0_CH1N	SPI1_MISO	USR0_RX	I2C0_SDA		EBI_AD3						
46			PC4				MT1_CH2		USR1_RTS			EBI_AD10		SD_CLK				
47			PC5				MT1_CH2N		USR1_CTS			EBI_AD11		SD_CMD				
48			PC6				MT1_CH3					EBI_AD12		SD_DAT0				
	35	32	VDD_2															
	36	33	VSS_2															
49	37	34	PB2				MT0_CH2	SPI0_SEL	UR0_TX			EBI_AD4						
50	38	35	PB3				MT0_CH2N	SPI0_SCK	UR0_RX			EBI_AD5						
51	39	36	PB4				MT0_BRK	SPI0_MOSI	UR1_TX			EBI_AD6						
52	40	37	PB5				MT1_BRK	SPI0_MISO	UR1_RX			EBI_AD7						
53			PC7				MT0_CH3			I2C0_SCL		EBI_AD8		SD_CMD				
54			PC8				MT0_ETI			I2C0_SDA		EBI_AD9		SD_CLK				
55			VDD_4															
56			VSS_4															
57	41	38	PB6			CN0	MT1_CH0	SPI1_SEL	UR1_TX			EBI_OE	I2S_MCLK					
58	42	39	PB7			CP0	MT1_CH0N	SPI1_SCK				EBI_CS0						
59	43	40	PB8			COUT0	GT1_ETI	SPI1_MOSI	UR1_RX			EBI_WE						
60	44	41	PB9			CN1	MT1_CH2	SPI1_MISO	UR0_TX			EBI_ALE	I2S_BCLK	SD_DAT1				
61	45	42	PB10			CP1	MT1_CH2N			I2C1_SCL		EBI_CS1	I2S_SDO	SD_DAT2				
62	46	43	PB11			COUT1	MT1_CH3		UR0_RX	I2C1_SDA		EBI_CS2	I2S_SDI	SD_DAT3				
63	47	44	VDDA															
64	48	45	VSSA															

Note: The EP is the exposed pad of the QFN package.

Table 4. Pin Description

Pin Number			Pin Name	Type ⁽¹⁾	I/O Structure ⁽²⁾	Output Driving	Description
64 LQFP	48 LQFP	46 QFN					Default Function (AF0)
1	1	46	PA0	AI/O	33V	4/8/12/16 mA	PA0
2	2	1	PA1	AI/O	33V	4/8/12/16 mA	PA1
3	3	2	PA2	AI/O	33V	4/8/12/16 mA	PA2, this pin provides a UART_TX function in the Boot loader mode.
4	4	3	PA3	AI/O	33V	4/8/12/16 mA	PA3, this pin provides a UART_RX function in the Boot loader mode.
5	5	4	PA4	AI/O	33V	4/8/12/16 mA	PA4
6	6	5	PA5	AI/O	33V	4/8/12/16 mA	PA5
7	7	6	PA6	AI/O	33V	4/8/12/16 mA	PA6
8	8	7	PA7	AI/O	33V	4/8/12/16 mA	PA7
9	9		VDD_3	P	—	—	Voltage for digital I/O
10	10	EP ⁽¹⁾	VSS_3	P	—	—	Ground reference for digital I/O
11			PC9	AI/O	33V	4/8/12/16 mA	PC9
12			PC10	AI/O	33V	4/8/12/16 mA	PC10
13			PC11	AI/O	33V	4/8/12/16 mA	PC11
14			PC12	AI/O	33V	4/8/12/16 mA	PC12
15	11	8	PB12	I/O	33V	4/8/12/16 mA	PB12
15	11	8	USBDM	AI/O	—	—	USB Differential data bus conforming to the Universal Serial Bus standard
16	12	9	USBDP	AI/O	—	—	USB Differential data bus conforming to the Universal Serial Bus standard
16	12	9	PB13	I/O	33V	4/8/12/16 mA	PB13
17	13	10	CLDO	P	—	—	Core power LDO 1.5 V output. It must be connected a 4.7 μF Tantalum capacitor as close as possible between this pin and VSS_1.
18	14	11	VDD_1	P	—	—	Voltage for digital I/O
19	15	12	VSS_1	P	—	—	Ground reference for digital I/O
20	16	13	nRST	I(BK ⁽¹⁾)	33V_PU	—	External reset pin and external wakeup pin in the Power-Down mode
21	17	14	VBAT	P	—	—	Battery power input for the backup domain
22	18	15	PC13 ⁽⁴⁾	AI/O(BK)	33V	< 2 mA	X32KIN
23	19	16	PC14 ⁽⁴⁾	AI/O(BK)	33V	< 2 mA	X32KOUT
24	20	17	PC15 ⁽⁴⁾	I/O(BK)	33V	< 2 mA	RTCOUT
25			PD0	I/O	33V	4/8/12/16 mA	PD0
26	21	18	PB14	AI/O	33V	4/8/12/16 mA	XTALIN
27	22	19	PB15	AI/O	33V	4/8/12/16 mA	XTALOUT
28	23	20	PD1	I/O	33V	4/8/12/16 mA	PD1
29	24	21	PD2	I/O	33V	4/8/12/16 mA	PD2
30			PC0	I/O	33V	4/8/12/16 mA	PC0
31			PC1	I/O	33V	4/8/12/16 mA	PC1
32			PC2	I/O	33V	4/8/12/16 mA	PC2
33			PC3	I/O	33V	4/8/12/16 mA	PC3
34	25	22	PA8	I/O	33V_PU	4/8/12/16 mA	PA8_BOOT0

Pin Number			Pin Name	Type ⁽¹⁾	I/O Structure ⁽²⁾	Output Driving	Description
64 LQFP	48 LQFP	46 QFN					Default Function (AF0)
35	26	23	PA9	I/O	33V_PU	4/8/12/16 mA	PA9_BOOT1
36	27	24	PA10	I/O	33V	4/8/12/16 mA	PA10
37	28	25	PA11	I/O	33V	4/8/12/16 mA	TRACESWO
38	29	26	PA12	I/O	33V_PU	4/8/12/16 mA	SWCLK
39	30	27	PA13	I/O	33V_PU	4/8/12/16 mA	SWDIO
40	31	28	PA14	I/O	33V_PU	4/8/12/16 mA	PA14
41	32	29	PA15	I/O	33V_PU	4/8/12/16 mA	PA15
42			VDD_2	P	—	—	Voltage for digital I/O
43			VSS_2	P	—	—	Ground reference for digital I/O
44	33	30	PB0	I/O	33V	4/8/12/16 mA	PB0
45	34	31	PB1	I/O	33V	4/8/12/16 mA	PB1
46			PC4	I/O	33V	4/8/12/16 mA	PC4
47			PC5	I/O	33V	4/8/12/16 mA	PC5
48			PC6	I/O	33V	4/8/12/16 mA	PC6
	35	32	VDD_2	P	—	—	Voltage for digital I/O
	36	33	VSS_2	P	—	—	Ground reference for digital I/O
49	37	34	PB2	I/O	33V	4/8/12/16 mA	PB2
50	38	35	PB3	I/O	33V	4/8/12/16 mA	PB3
51	39	36	PB4	I/O	33V	4/8/12/16 mA	PB4
52	40	37	PB5	I/O	33V	4/8/12/16 mA	PB5
53			PC7	I/O	33V	4/8/12/16 mA	PC7
54			PC8	I/O	33V	4/8/12/16 mA	PC8
55			VDD_4	P	—	—	Voltage for digital I/O
56			VSS_4	P	—	—	Ground reference for digital I/O
57	41	38	PB6	AI/O	33V	4/8/12/16 mA	PB6
58	42	39	PB7	AI/O	33V	4/8/12/16 mA	PB7
59	43	40	PB8	AI/O	33V	4/8/12/16 mA	PB8
60	44	41	PB9	AI/O	33V	4/8/12/16 mA	PB9
61	45	42	PB10	AI/O	33V	4/8/12/16 mA	PB10
62	46	43	PB11	AI/O	33V	4/8/12/16 mA	PB11
63	47	44	VDDA	P	—	—	Analog voltage for ADC and Comparator
64	48	45	VSSA	P	—	—	Ground reference for the ADC and Comparator

Note: 1. I = Input, O = Output, A = Analog port, P = Power supply, PU = Pull-up, BK = Backup domain, EP = Exposed pad of the QFN package.

2. 33V = 3.3 V tolerant.

3. The GPIOs are in an AF0 state after a V_{DD15} power on reset (POR) except for the RTCOUT pin in the Backup Domain I/O. The RTCOUT pin is reset by the Backup Domain power-on-reset (PORB) or by the Backup Domain software reset (BAK_RST bit in BAK_CR register).

4. The backup domain of the I/O pins have a source current capability limitation of < 2 mA @ V_{DD} = 3.3 V and sink current typical is 4/8 mA configurable @ V_{DD} = 3.3 V.

5. In the Boot loader mode, the UART and USB interfaces are available for communication.

5 Electrical Characteristics

Absolute Maximum Ratings

The following table shows the absolute maximum ratings of the device. These are stress ratings only. Stresses beyond absolute maximum ratings may cause permanent damage to the device. Note that the device is not guaranteed to operate properly at the maximum ratings. Exposure to the absolute maximum rating conditions for extended periods may affect device reliability.

Table 5. Absolute Maximum Ratings

Symbol	Parameter	Min.	Max.	Unit.
V _{DD}	External main supply voltage	V _{SS} - 0.3	V _{SS} + 3.6	V
V _{DDA}	External analog supply voltage	V _{SSA} - 0.3	V _{SSA} + 3.6	V
V _{BAT}	External battery supply voltage	V _{SS} - 0.3	V _{SS} + 3.6	V
V _{IN}	Input voltage on other I/O	V _{SS} - 0.3	V _{DD} + 0.3	V
T _A	Ambient operating temperature range	-40	85	°C
T _{STG}	Storage temperature range	-55	150	°C
T _J	Maximum junction temperature	—	125	°C
P _D	Total power dissipation	—	500	mW
V _{ESD}	Electrostatic discharge voltage - human body mode	-4000	4000	V

Recommended DC Operating Conditions

Table 6. Recommended DC Operating Conditions

T_A = 25 °C, unless otherwise specified.

Symbol	Parameter	Conditions	Min.	Typ.	Max.	Unit
V _{DD}	I/O operating voltage	—	2.0	3.3	3.6	V
V _{DDA}	Analog operating voltage	—	2.5	3.3	3.6	V
V _{BAT}	Battery supply operating voltage	—	2.0	3.3	3.6	V

On-Chip LDO Voltage Regulator Characteristics

Table 7. LDO Characteristics

T_A = 25 °C, unless otherwise specified.

Symbol	Parameter	Conditions	Min.	Typ.	Max.	Unit
V _{LDO}	Internal regulator output voltage	V _{DD} ≥ 2.0 V Regulator input @ I _{LDO} = 35 mA and voltage variant = ±5 %, After trimming	1.425	1.5	1.57	V
I _{LDO}	Output current	V _{DD} = 2.0 V Regulator input @ V _{LDO} = 1.5 V	—	50	75	mA

Symbol	Parameter	Conditions	Min.	Typ.	Max.	Unit
C _{LDO}	External filter capacitor value for internal core power supply	The Tantalum capacitor value is dependent on the core power current consumption	2.2	4.7	—	μF
		The MLCC capacitor value is dependent on the core power current consumption	10	—	—	

Power Consumption

Table 8. Power Consumption Characteristics

T_A = 25 °C, unless otherwise specified.

Symbol	Parameter	f _{HCLK}	Conditions	Min.	Typ.	Max.	Unit		
I _{DD}	Supply current (Run mode)	96 MHz	V _{DD} = V _{BAT} = 3.3 V HSI = 8 MHz PLL = 96 MHz All peripherals enabled	—	42	—	mA		
			All peripherals disabled	—	22	—			
		72 MHz	V _{DD} = V _{BAT} = 3.3 V HSI = 8 MHz PLL = 72 MHz All peripherals enabled	—	35	—			
			All peripherals disabled	—	20	—			
		48 MHz	V _{DD} = V _{BAT} = 3.3 V HSI = 8 MHz PLL = 96 MHz All peripherals enabled	—	28	—			
			All peripherals disabled	—	17	—			
		24 MHz	V _{DD} = V _{BAT} = 3.3 V HSI = 8 MHz PLL = 96 MHz All peripherals enabled	—	17	—			
			All peripherals disabled	—	10	—			
		8 MHz	V _{DD} = V _{BAT} = 3.3 V HSI = 8 MHz PLL = off All peripherals enabled	—	8.0	—			
			All peripherals disabled	—	5.0	—			
		1 MHz	V _{DD} = V _{BAT} = 3.3 V HSI = 8 MHz PLL = off All peripherals enabled	—	3.0	—			
			All peripherals disabled	—	2.7	—			
		32 kHz	V _{DD} = V _{BAT} = 3.3 V LSI = 32 kHz LDO low current mode	All peripherals enabled	—	75		—	μA
				All peripherals disabled	—	65		—	
Supply current (Sleep mode)	96 MHz	V _{DD} = V _{BAT} = 3.3 V HSI = 8 MHz PLL = 96 MHz MCU core sleep All peripherals enabled	—	27.5	—	mA			
		All peripherals disabled	—	3.5	—				
Supply current (Deep-Sleep1 mode)	—	—	V _{DD} = V _{BAT} = 3.3 V, All clock off (HSI/PLL/f _{HCLK}), LDO in low power mode, LSE off, LSI on, RTC on	—	30	—	μA		
Supply current (Deep-Sleep2 mode)	—	—	V _{DD} = V _{BAT} = 3.3 V, All clock off (HSI/PLL/f _{HCLK}), LDO off (DMOS on), LSE off, LSI on, RTC on	—	5.0	—	μA		
Supply current (Power-Down mode)	—	—	V _{DD} = V _{BAT} = 3.3 V, LDO off, LSE on, LSI on, RTC on	—	3.1	—	μA		
			V _{DD} = V _{BAT} = 3.3 V, LDO off, LSE off, LSI on, RTC off	—	1.6	—	μA		

Symbol	Parameter	f _{HCLK}	Conditions	Min.	Typ.	Max.	Unit
I _{BAT}	Battery supply current (Power-Down mode)	—	V _{DD} not present, V _{BAT} = 3.3 V, LDO off, LSE on, LSI on, RTC on	—	2.7	—	μA
			V _{DD} not present, V _{BAT} = 3.3 V, LDO off, LSE off, LSI on, RTC off	—	1.3	—	μA

Note: 1. HSE means high speed external oscillator. HSI means 8 MHz high speed internal oscillator.
 2. LSE means 32.768 kHz low speed external oscillator. LSI means 32 kHz low speed internal oscillator.
 3. RTC means real time clock.
 4. Code = while (1) { 208 NOP } executed in Flash.

Reset and Supply Monitor Characteristics

Table 9. V_{DD} Power Reset Characteristics

T_A = 25 °C, unless otherwise specified.

Symbol	Parameter	Conditions	Min.	Typ.	Max.	Unit
V _{POR}	Power on reset threshold (Rising Voltage on V _{DD})	T _A = -40 °C ~ 85 °C	1.66	1.79	1.90	V
V _{PDR}	Power down reset threshold (Falling Voltage on V _{DD})		1.49	1.64	1.78	V
V _{PORHYST}	POR hysteresis	—	—	150	—	mV
t _{POR}	Reset delay time	V _{DD} = 3.3 V	—	0.1	0.2	ms

Note: 1. Data based on characterization results only, not tested in production.
 2. Guaranteed by design, not tested in production.
 3. If the LDO will be turn on, the V_{DD} POR has to be in the de-assertion condition. When the V_{DD} POR is in the assertion state then the LDO will be turn off.

Table 10. LVD/BOD Characteristics

T_A = 25 °C, unless otherwise specified.

Symbol	Parameter	Conditions	Min.	Typ.	Max.	Unit	
V _{BOD}	Voltage of Brown Out Detection	T _A = -40 °C ~ 85 °C After factory-trimmed (V _{DD} Falling edge)	2.02	2.1	2.18	V	
V _{LVD}	Voltage of Low Voltage Detection	T _A = -40 °C ~ 85 °C (V _{DD} Falling edge)	LVDS = 000	2.17	2.25	2.33	V
			LVDS = 001	2.32	2.4	2.48	V
			LVDS = 010	2.47	2.55	2.63	V
			LVDS = 011	2.62	2.7	2.78	V
			LVDS = 100	2.77	2.85	2.93	V
			LVDS = 101	2.92	3.0	3.08	V
			LVDS = 110	3.07	3.15	3.23	V
			LVDS = 111	3.22	3.3	3.38	V
V _{LVDHTST}	LVD hysteresis	V _{DD} = 3.3 V	—	—	100	mV	
t _{SULVD}	LVD Setup time	V _{DD} = 3.3 V	—	—	5	μs	
t _{ATLVD}	LVD active delay time	V _{DD} = 3.3 V	—	—	—	μs	

Symbol	Parameter	Conditions	Min.	Typ.	Max.	Unit
I _{DDLVD}	Operation current ⁽³⁾	V _{DD} = 3.3 V	—	5	15	μA

- Note: 1. Data based on characterization results only, not tested in production.
 2. Guaranteed by design, not tested in production.
 3. Bandgap current is not included.
 4. LVDS field is in PWRCU LVDCSR register.

External Clock Characteristics

Table 11. High Speed External Clock (HSE) Characteristics

T_A = 25 °C, unless otherwise specified.

Symbol	Parameter	Conditions	Min.	Typ.	Max.	Unit
V _{DD}	Operation Range	—	2.0	—	3.6	V
f _{HSE}	High Speed External oscillator frequency (HSE)	—	4	—	16	MHz
C _{LHSE}	Load capacitance	V _{DD} = 3.3 V, R _{ESR} = 100 Ω @ 16 MHz	—	—	22	pF
R _{FHSE}	Internal feedback resistor between XTALIN and XTALOUT pins	V _{DD} = 3.3 V	—	1	—	MΩ
R _{ESR}	Equivalent Series Resistance	V _{DD} = 3.3 V, C _L = 12 pF @ 16 MHz, HSEDR = 0	—	—	100	Ω
		V _{DD} = 2.4 V, C _L = 12 pF @ 16 MHz, HSEDR = 1	—	—	200	
D _{HSE}	HSE oscillator Duty cycle	—	40	—	60	%
I _{DDHSE}	HSE oscillator current consumption	V _{DD} = 3.3 V C _L = 12 pF HSEDR = 0	8 MHz —	0.75	—	mA
			16 MHz —	1	—	
I _{PWDHSE}	HSE oscillator power down current	V _{DD} = 3.3 V	—	—	0.01	μA
t _{SUHSE}	HSE oscillator startup time	V _{DD} = 3.3 V @ 8 MHz, HSEDR = 0	—	—	4	ms

Table 12. Low Speed External Clock (LSE) Characteristics

T_A = 25 °C, unless otherwise specified.

Symbol	Parameter	Conditions	Min.	Typ.	Max.	Unit
V _{BAK}	Operation Range	—	2.0	—	3.6	V
f _{CK_LSE}	Frequency of LSE	V _{BAK} = 2.0 V ~ 3.6 V	—	32.768	—	kHz
R _F	Internal feedback resistor	—	—	10	—	MΩ
R _{ESR}	Equivalent Series Resistance	V _{BAK} = 3.3 V	30	—	TBD	kΩ
C _L	Recommended load capacitances	V _{BAK} = 3.3 V	6	—	TBD	pF

Symbol	Parameter	Conditions	Min.	Typ.	Max.	Unit
I _{DDLSE}	Oscillator supply current (High current mode)	f _{CK_LSE} = 32.768 kHz, R _{ESR} = 50 kΩ, C _L ≥ 7 pF V _{BAK} = 2.0V ~ 2.7 V, T _A = -40 °C ~ 85 °C	—	3.3	6.3	μA
	Oscillator supply current (Low current mode)	f _{CK_LSE} = 32.768 kHz, R _{ESR} = 50 kΩ, C _L < 7 pF V _{BAK} = 2.0 V ~ 3.6 V, T _A = -40 °C ~ 85 °C	—	1.8	3.3	μA
	Power down current	—	—	—	0.01	μA
t _{SULSE}	Startup time (Low current mode)	f _{CK_LSE} = 32.768 kHz, V _{BAK} = 2.7 V ~ 3.6 V	—	2.5	—	s

Note: The following guidelines are recommended to increase the robustness of the crystal circuit of the HSE / LSE clock in the PCB layout phase.

1. The crystal oscillator should be located as close as possible to the MCU so that the trace length would be as short as possible to reduce the parasitic capacitance.
2. Shield lines in the vicinity of the crystal by using a ground plane to isolate signals and reduce noise.
3. Keep the frequently switching signal lines away from the crystal area to prevent the crosstalk.

Internal Clock Characteristics

Table 13. High Speed Internal Clock (HSI) Characteristics

T_A = 25 °C, unless otherwise specified.

Symbol	Parameter	Conditions	Min.	Typ.	Max.	Unit
V _{DD}	Operation Range	—	2.0	—	3.6	V
f _{HSI}	Frequency of HSI	V _{DD} = 3.3 V @ 25 °C	—	8	—	MHz
ACC _{HSI}	Frequency accuracy of the factory-calibrated HSI oscillator	V _{DD} = 3.3 V, T _A = 25 °C	-2	—	2	%
		V _{DD} = 2.5 V ~ 3.6 V, T _A = -40 °C ~ 85 °C	-3	—	3	%
		V _{DD} = 2.0 V ~ 3.6 V T _A = -40 °C ~ 85 °C	-4	—	4	%
Duty	Duty cycle	f _{HSI} = 8 MHz	35	—	65	%
I _{DDHSI}	Oscillator supply current	f _{HSI} = 8 MHz	—	220	250	μA
	Power down current		—	—	0.05	μA
t _{SUHSI}	Startup time	f _{HSI} = 8 MHz	—	—	10	μs

Table 14. Low Speed Internal Clock (LSI) Characteristics

T_A = 25 °C, unless otherwise specified.

Symbol	Parameter	Conditions	Min.	Typ.	Max.	Unit
f _{LSI}	Low Speed Internal Oscillator Frequency (LSI)	V _{BAK} = 3.3 V, T _A = -40 °C ~ 85 °C	21	32	43	kHz
ACC _{LSI}	Frequency accuracy of LSI	After factory-trimmed, V _{BAK} = 3.3 V, T _A = 25 °C	-10	—	+10	%
I _{DDL SI}	LSI Oscillator Operating current	V _{BAK} = 3.3 V, T _A = 25 °C	—	0.8	1.2	μA
t _{SULSI}	LSI Oscillator startup time	V _{BAK} = 3.3 V, T _A = 25 °C	—	—	100	μs

PLL Characteristics

Table 15. PLL Characteristics

$T_A = 25\text{ }^\circ\text{C}$, unless otherwise specified.

Symbol	Parameter	Conditions	Min.	Typ.	Max.	Unit
f_{PLLIN}	PLL input clock	—	4	—	16	MHz
$f_{\text{CK_PLL}}$	PLL output clock	—	64	—	96	MHz
t_{LOCK}	PLL lock time	—	—	200	—	μs

USB PLL Characteristics

Table 16. USB PLL Characteristics

$T_A = 25\text{ }^\circ\text{C}$, unless otherwise specified.

Symbol	Parameter	Conditions	Min.	Typ.	Max.	Unit
f_{PLLIN}	PLL input clock	—	4	—	16	MHz
$f_{\text{CK_PLL}}$	PLL output clock	—	16	—	48	MHz
t_{LOCK}	PLL lock time	—	—	200	—	μs

Memory Characteristics

Table 17. Flash Memory Characteristics

$T_A = 25\text{ }^\circ\text{C}$, unless otherwise specified.

Symbol	Parameter	Conditions	Min.	Typ.	Max.	Unit
N_{ENDU}	Number of guaranteed program/erase cycles before failure(Endurance)	$T_A = -40\text{ }^\circ\text{C} \sim 85\text{ }^\circ\text{C}$	10	—	—	K cycles
t_{RET}	Data retention time	$T_A = -40\text{ }^\circ\text{C} \sim 85\text{ }^\circ\text{C}$	10	—	—	Years
t_{PROG}	Word programming time	$T_A = -40\text{ }^\circ\text{C} \sim 85\text{ }^\circ\text{C}$	20	—	—	μs
t_{ERASE}	Page erase time	$T_A = -40\text{ }^\circ\text{C} \sim 85\text{ }^\circ\text{C}$	2	—	—	ms
t_{MERASE}	Mass erase time	$T_A = -40\text{ }^\circ\text{C} \sim 85\text{ }^\circ\text{C}$	10	—	—	ms

I/O Port Characteristics

Table 18. I/O Port Characteristics

$T_A = 25\text{ }^\circ\text{C}$, unless otherwise specified.

Symbol	Parameter	Conditions		Min.	Typ.	Max.	Unit
I_{IL}	Low level input current	3.3 V I/O	$V_I = V_{\text{SS}}$, On-chip pull-up resistor disabled	—	—	3	μA
		Reset pin	$V_I = V_{\text{SS}}$, On-chip pull-up resistor disabled	—	—	3	μA
I_{IH}	High level input current	3.3 V I/O	$V_I = V_{\text{DD}}$, On-chip pull-down resistor disabled	—	—	3	μA
		Reset pin	$V_I = V_{\text{DD}}$, On-chip pull-down resistor disabled	—	—	3	μA

Symbol	Parameter	Conditions	Min.	Typ.	Max.	Unit	
V _{IL}	Low level input voltage	3.3 V I/O	-0.5	—	0.35 V _{DD}	V	
		Reset pin	-0.5	—	0.35 V _{DD}	V	
V _{IH}	High level input voltage	3.3 V I/O	0.65 V _{DD}	—	V _{DD} + 0.5	V	
		Reset pin	0.65 V _{DD}	—	V _{DD} + 0.5	V	
V _{HYS}	Schmitt trigger input voltage hysteresis	3.3 V I/O	—	0.12 V _{DD}	—	mV	
		Reset pin	—	0.12 V _{DD}	—	mV	
I _{OL}	Low level output current (GPIO Sink current)	3.3 V I/O 4 mA drive, V _{OL} = 0.4 V	4	—	—	mA	
		3.3 V I/O 8 mA drive, V _{OL} = 0.4 V	8	—	—	mA	
		3.3 V I/O 12 mA drive, V _{OL} = 0.4 V	12	—	—	mA	
		3.3 V I/O 16 mA drive, V _{OL} = 0.4 V	16	—	—	mA	
		Backup Domain I/O drive @ V _{DD} = 3.3 V, V _{OL} = 0.4 V, PB10, PB11, PB12	4	—	—	mA	
I _{OH}	High level output current (GPIO Source current)	3.3 V I/O 4 mA drive, V _{OH} = V _{DD} - 0.4 V	4	—	—	mA	
		3.3 V I/O 8 mA drive, V _{OH} = V _{DD} - 0.4 V	8	—	—	mA	
		3.3 V I/O 12 mA drive, V _{OH} = V _{DD} - 0.4 V	12	—	—	mA	
		3.3 V I/O 16 mA drive, V _{OH} = V _{DD} - 0.4 V	16	—	—	mA	
		Backup Domain I/O drive @ V _{DD} = 3.3 V, V _{OL} = V _{DD} - 0.4 V, PB10, PB11, PB12.	—	—	2	mA	
V _{OL}	Low level output voltage	3.3 V 4 mA drive I/O, I _{OL} = 4 mA	—	—	0.4	V	
		3.3 V 8 mA drive I/O, I _{OL} = 8 mA	—	—	0.4	V	
		3.3 V 12 mA drive I/O, I _{OL} = 12 mA	—	—	0.4	V	
		3.3 V 16 mA drive I/O, I _{OL} = 16 mA	—	—	0.4	V	
		Backup Domain I/O Sink Current = 4 mA (Low driving strength)	V _{DD} = 2.7 V ~ 3.6 V	—	—	0.4	V
			V _{DD} = 2.0 V ~ 2.7 V	—	—	0.6	V
		Backup Domain I/O Sink Current = 8 mA (High driving strength)	V _{DD} = 2.7 V ~ 3.6 V	—	—	0.4	V
V _{DD} = 2.0 V ~ 2.7 V	—		—	0.6	V		

Symbol	Parameter	Conditions	Min.	Typ.	Max.	Unit	
V _{OH}	High level output voltage	3.3 V 4 mA drive I/O, I _{OH} = 4 mA	V _{DD} - 0.4	—	—	V	
		3.3 V 8 mA drive I/O, I _{OH} = 8 mA	V _{DD} - 0.4	—	—	V	
		3.3 V 12 mA drive I/O, I _{OL} = 12 mA	V _{DD} - 0.4	—	—	V	
		3.3 V 16 mA drive I/O, I _{OL} = 16 mA	V _{DD} - 0.4	—	—	V	
		Backup Domain I/O Source Current = 2 mA	V _{DD} = 2.7 V ~ 3.6 V	2.4	—	—	V
		Backup Domain I/O Source Current = 1 mA	V _{DD} = 2.0 V ~ 2.7 V	V _{DD} - 0.4	—	—	V
R _{PU}	Internal pull-up resistor	3.3 V I/O	—	46	—	kΩ	
R _{PD}	Internal pull-down resistor	3.3 V I/O	—	46	—	kΩ	

ADC Characteristics

Table 19. ADC Characteristics

T_A = 25 °C, unless otherwise specified.

Symbol	Parameter	Conditions	Min.	Typ.	Max.	Unit
V _{DDA}	Operating voltage	—	2.5	3.3	3.6	V
V _{ADCIN}	A/D Converter input voltage range	—	0	—	V _{REF+}	V
V _{REF+}	A/D Converter Reference voltage	—	—	V _{DDA}	V _{DDA}	V
I _{ADC}	Current consumption	V _{DDA} = 3.3 V	—	0.85	1	mA
I _{ADC_DN}	Power down current consumption	V _{DDA} = 3.3 V	—	—	0.1	μA
f _{ADC}	A/D Converter clock	—	0.7	—	16	MHz
f _S	Sampling rate	—	0.05	—	1	MHz
t _{DL}	Data latency	—	—	12.5	—	1/f _{ADC} Cycles
t _{S&H}	Sampling & hold time	—	—	3.5	—	1/f _{ADC} Cycles
t _{ADCCONV}	A/D Converter conversion time	—	—	16	—	1/f _{ADC} Cycles
R _I	Input sampling switch resistance	—	—	—	1	kΩ
C _I	Input sampling capacitance	No pin/pad capacitance included	—	16	—	pF
t _{SU}	Startup time	—	—	—	1	μs
N	Resolution	—	—	12	—	bits

Symbol	Parameter	Conditions	Min.	Typ.	Max.	Unit
INL	Integral Non-linearity error	$f_s = 750 \text{ kHz}, V_{DDA} = 3.3 \text{ V}$	—	± 2	± 5	LSB
DNL	Differential Non-linearity error	$f_s = 750 \text{ kHz}, V_{DDA} = 3.3 \text{ V}$	—	± 1	—	LSB
E_o	Offset error	—	—	—	± 10	LSB
E_G	Gain error	—	—	—	± 10	LSB

- Note: 1. Guaranteed by design, not tested in production.
2. Due to the A/D Converter input channel and GPIO pin-shared function design limitation, the V_{DDA} supply power of the A/D Converter has to be equal to the V_{DD} supply power of the MCU in the application circuit.
3. The figure below shows the equivalent circuit of the A/D Converter Sample-and-Hold input stage where C_I is the storage capacitor, R_I is the resistance of the sampling switch and R_S is the output impedance of the signal source V_S . Normally the sampling phase duration is approximately, $3.5/f_{ADC}$. The capacitance, C_I , must be charged within this time frame and it must be ensured that the voltage at its terminals becomes sufficiently close to V_S for accuracy. To guarantee this, R_S may not have an arbitrarily large value.

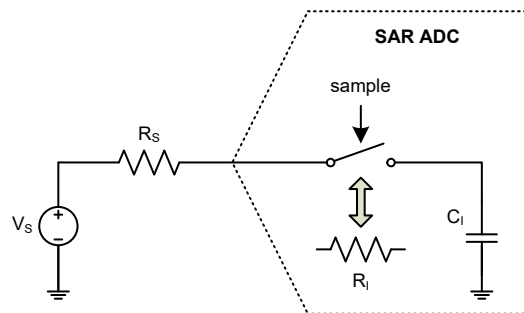

Figure 7. Figure 7 ADC Sampling Network Model

The worst case occurs when the extremities of the input range ($0V$ and V_{REF}) are sampled consecutively. In this situation a sampling error below $\frac{1}{4}$ LSB is ensured by using the following equation:

$$R_S < \frac{3.5}{f_{ADC} C_I \ln(2^{N+2})} - R_I$$

Where f_{ADC} is the ADC clock frequency and N is the ADC resolution ($N = 12$ in this case). A safe margin should be considered due to the pin/pad parasitic capacitances, which are not accounted for in this simple model.

If in a system where the A/D Converter is used, there are no rail-to-rail input voltage variations between consecutive sampling phases, R_S may be larger than the value indicated by the equation above.

Comparator Characteristics

Table 20. Comparator Characteristics

T_A = 25 °C, unless otherwise specified.

Symbol	Parameter	Conditions	Min.	Typ.	Max.	Unit	
V _{DDA}	Operating voltage	Comparator mode	2.5	3.3	3.6	V	
V _{IN}	Input Common Mode Voltage Range	CP or CN	V _{SSA}	—	V _{DDA}	V	
V _{IOS}	Input offset voltage ⁽¹⁾	T _A = 25 °C	-15	—	15	mV	
V _{HYS}	Input Hysteresis	No hysteresis (CMPnHM[1:0] = 00)	Low Speed	—	0	—	mV
			High Speed	—	0	—	
		Low hysteresis (CMPnHM[1:0] = 01)	Low Speed	—	30	—	mV
			High Speed	—	30	—	
		Middle hysteresis (CMPnHM[1:0] = 10)	Low Speed	—	50	—	mV
			High Speed	—	70	—	
		High hysteresis (CMPnHM[1:0] = 11)	Low Speed	—	70	—	mV
			High Speed	—	100	—	
t _{RT}	Response time Input Overdrive = ±100mV	High Speed mode	V _{DDA} ≥ 2.7 V	—	50	100	ns
			V _{DDA} < 2.7 V	—	100	250	
		Low Speed mode	—	2	5	μs	
I _{CMP}	Current Consumption V _{DDA} = 3.3 V	High Speed mode	—	180	—	μA	
		Low Speed mode	—	30	—	μA	
t _{CMPST}	Comparator Startup Time	Comparator enabled to output valid	—	—	50	μs	
I _{CMP_DN}	Power Down Supply Current	CMPEN = 0, CVREFEN = 0 CVREFOE = 0	—	—	0.1	μA	
Comparator Voltage Reference (CVR)							
V _{CVR}	Output Range	—	V _{SSA}	—	V _{DDA}	V	
N _{Bits}	CVR Scaler Resolution	—	—	6	—	bits	
t _{CVRST}	Setting Time	CVR scaler setting time from CVREF = "000000" to "111111"	—	—	100	μs	
I _{CVR}	Current Consumption V _{DDA} = 3.3 V	CVREFEN = 1, CMPREFOE = 0	—	65	—	μA	
		CVREFEN = 1, CVREFOE = 1	—	80	110	μA	

Note: Guaranteed by design, not tested in production.

GPTM/MCTM Characteristics

Table 21. GPTM/MCTM Characteristics

Symbol	Parameter	Conditions	Min.	Typ.	Max.	Unit
f_{TM}	Timer clock source for GPTM and MCTM	—	—	—	96	MHz
t_{RES}	Timer resolution time	—	1	—	—	$1/f_{TM}$
f_{EXT}	External single frequency on channel 1 ~ 4	—	—	—	1/2	f_{TM}
RES	Timer resolution	—	—	—	16	bits

I²C Characteristics

Table 22. I²C Characteristics

Symbol	Parameter	Standard Mode		Fast Mode		Fast Mode Plus		Unit
		Min.	Max.	Min.	Max.	Min.	Max.	
f_{SCL}	SCL clock frequency	—	100	—	400	—	1000	kHz
$t_{SCL(H)}$	SCL clock high time	4.5	—	1.125	—	0.45	—	μ s
$t_{SCL(L)}$	SCL clock low time	4.5	—	1.125	—	0.45	—	μ s
t_{FALL}	SCL and SDA fall time	—	1.3	—	0.34	—	0.135	μ s
t_{RISE}	SCL and SDA rise time	—	1.3	—	0.34	—	0.135	μ s
$t_{SU(SDA)}$	SDA data setup time	500	—	125	—	50	—	ns
$t_{H(SDA)}$	SDA data hold time (Note 5)	0	—	0	—	0	—	ns
	SDA data hold time (Note 6)	100	—	100	—	100	—	ns
$t_{VD(SDA)}$	SDA data valid time	—	1.6	—	0.475	—	0.25	μ s
$t_{SU(STA)}$	START condition setup time	500	—	125	—	50	—	ns
$t_{H(STA)}$	START condition hold time	0	—	0	—	0	—	ns
$t_{SU(STO)}$	STOP condition setup time	500	—	125	—	50	—	ns

- Note: 1. Guaranteed by design, not tested in production.
 2. To achieve 100 kHz standard mode, the peripheral clock frequency must be higher than 2 MHz.
 3. To achieve 400 kHz fast mode, the peripheral clock frequency must be higher than 8 MHz.
 4. To achieve 1 MHz fast mode plus, the peripheral clock frequency must be higher than 20 MHz.
 5. The above characteristic parameters of the I²C bus timing are based on: COMB_FILTER_En = 0 and SEQ_FILTER = 00.
 6. The above characteristic parameters of the I²C bus timing are based on: COMB_FILTER_En = 1 and SEQ_FILTER = 00.

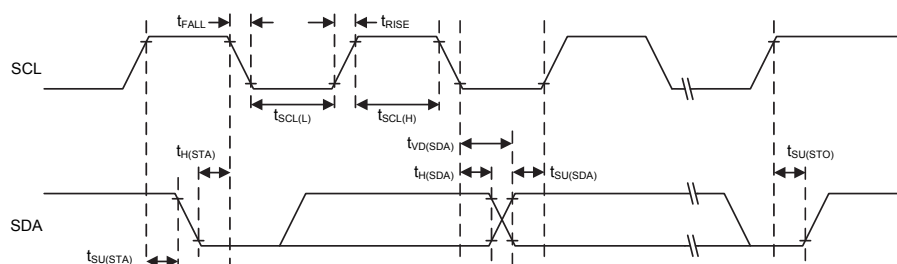

Figure 8. I²C Timing Diagrams

SPI Characteristics

Table 23. SPI Characteristics

Symbol	Parameter	Conditions	Min.	Typ.	Max.	Unit
SPI Master mode						
f_{SCK} ($1/t_{SCK}$)	SPI master output SCK clock frequency	Master mode SPI peripheral clock frequency f_{PCLK}	—	—	$f_{PCLK}/2$	MHz
$t_{SCK(H)}$ $t_{SCK(L)}$	SCK clock high and low time	—	$t_{SCK}/2 - 2$	—	$t_{SCK}/2 + 1$	ns
$t_{V(MO)}$	Data output valid time	—	—	—	5	ns
$t_{H(MO)}$	Data output hold time	—	2	—	—	ns
$t_{SU(MI)}$	Data input setup time	—	5	—	—	ns
$t_{H(MI)}$	Data input hold time	—	5	—	—	ns
SPI Slave mode						
f_{SCK} ($1/t_{SCK}$)	SPI slave input SCK clock frequency	Slave mode SPI peripheral clock frequency f_{PCLK}	—	—	$f_{PCLK}/3$	MHz
$Duty_{SCK}$	SPI slave input SCK clock duty cycle	—	30	—	70	%
$t_{SU(SEL)}$	SEL enable setup time	—	$3 \times t_{PCLK}$	—	—	ns
$t_{H(SEL)}$	SEL enable hold time	—	$2 \times t_{PCLK}$	—	—	ns
$t_{A(SO)}$	Data output access time	—	—	—	$3 \times t_{PCLK}$	ns
$t_{DIS(SO)}$	Data output disable time	—	—	—	10	ns
$t_{V(SO)}$	Data output valid time	—	—	—	25	ns
$t_{H(SO)}$	Data output hold time	—	15	—	—	ns
$t_{SU(SI)}$	Data input setup time	—	5	—	—	ns
$t_{H(SI)}$	Data input hold time	—	4	—	—	ns

Note: $t_{SCK} = 1/f_{SCK}$; $t_{PCLK} = 1/f_{PCLK}$. SPI output (input) clock frequency f_{SCK} ; SPI peripheral clock frequency f_{PCLK} .

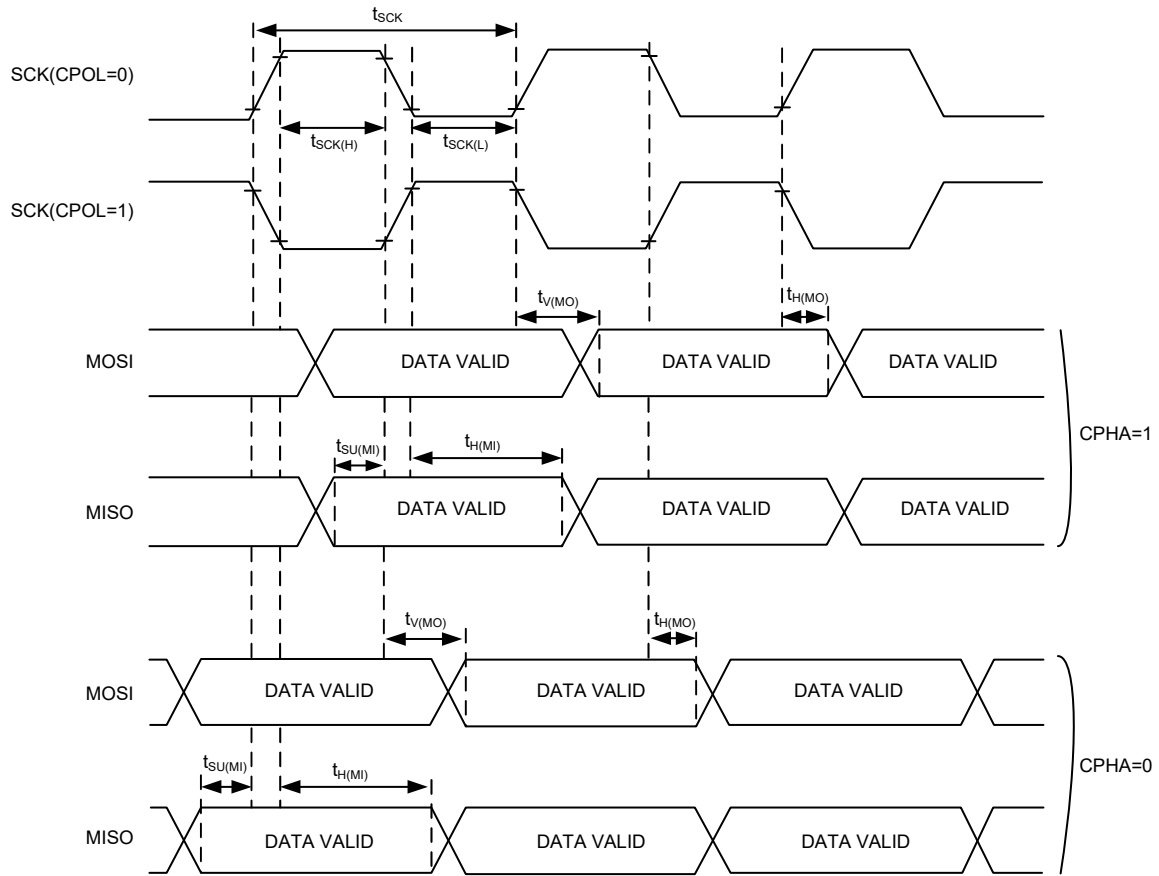

Figure 9. SPI Timing Diagrams – SPI Master Mode

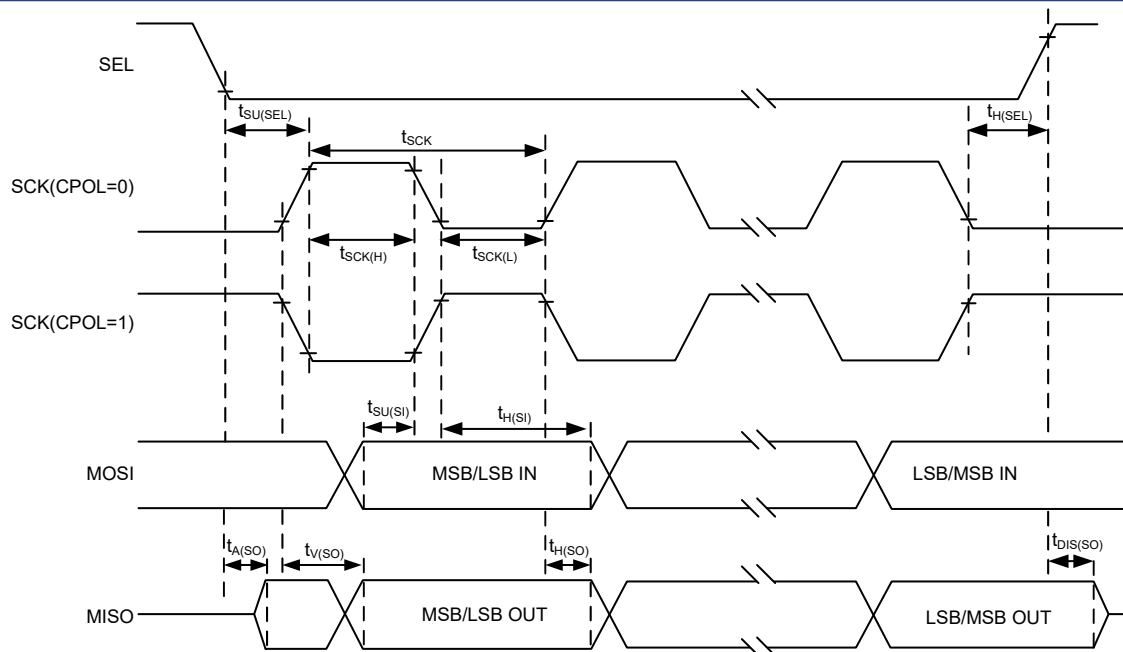

Figure 10. SPI Timing Diagrams - SPI Slave Mode with CPHA = 1

I²S Characteristics

Table 24. I²S Characteristics

Symbol	Parameter	Conditions	Min.	Typ.	Max.	Unit
I²S Master mode						
$t_{WSD(MO)}$	WS output to BCLK delay	—	0	—	4.6	ns
$t_{DOD(MO)}$	Data output to BCLK delay	—	0.5	—	5.4	ns
$t_{DIS(MI)}$	Data input setup time	—	0	—	—	ns
$t_{DIH(MI)}$	Data input hold time	—	13	—	—	ns
I²S Slave mode						
$t_{BCH(SI)}$	BCLK high pulse width	—	42	—	—	ns
$t_{BCL(SI)}$	BCLK low pulse width	—	42	—	—	ns
$t_{WSS(SI)}$	WS input setup time	—	0	—	—	ns
$t_{DOD(SO)}$	Data output to BCLK delay	—	—	—	9	ns
$t_{DIS(SI)}$	Data input setup time	—	0	—	—	ns
$t_{DIH(SI)}$	Data input hold time	—	2.1	—	—	ns

- Note: 1. Guaranteed by characterization results, not tested in production.
 2. I/O driving current is set to 4 mA.
 3. Capacitive load C = 10 pF, V_{DD} = 3.3 V and ambient temperature T_A = 25 °C.
 4. Measurement points are set at CMOS levels = 0.5 V_{DD}.

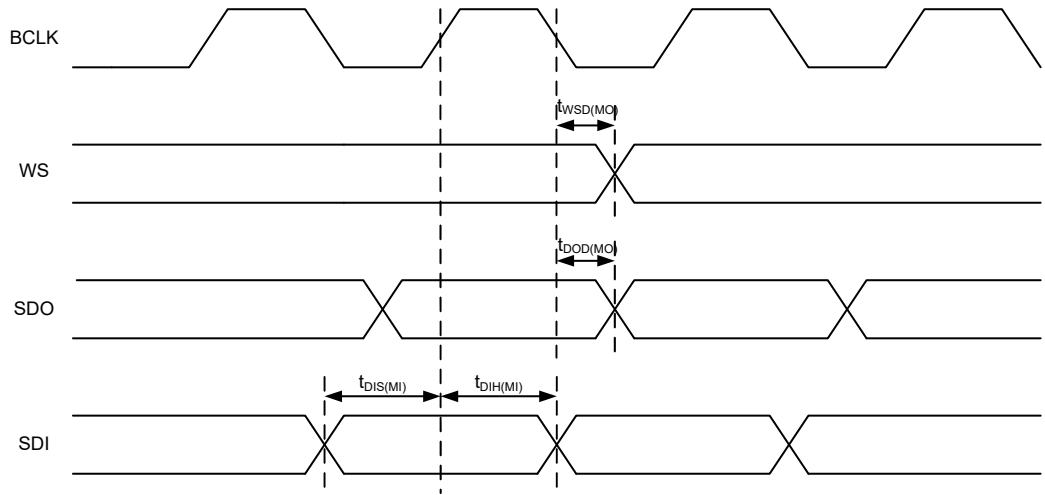

Figure 11. Timing of I²S Master Mode

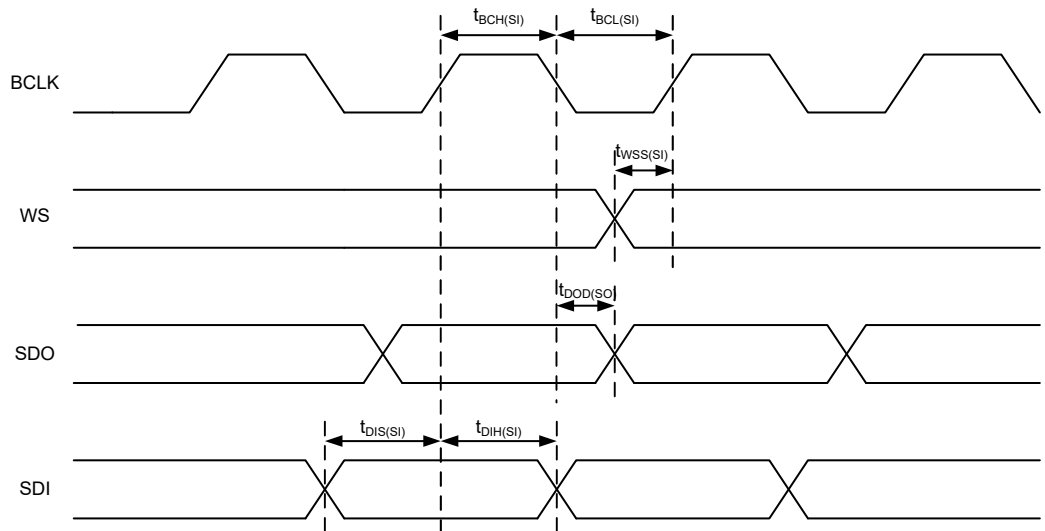

Figure 12. Timing of I²S Slave Mode

SDIO Characteristics

Table 25. SDIO Characteristics

Symbol	Parameter	Conditions	Min.	Typ.	Max.	Unit
f_{SDCK}	Clock frequency in data transfer mode	—	—	—	48	MHz
$t_{W(CKL)}$	Clock low time	$f_{SDCK} = 48 \text{ MHz}$	—	9	—	ns
$t_{W(CKH)}$	Clock high time	$f_{SDCK} = 48 \text{ MHz}$	—	10	—	ns
CMD, Data inputs referenced to SD_CLK in SD default mode						
$t_{ISU(SD)}$	Input setup time SD default mode	$f_{SDCK} = 24 \text{ MHz}$	3	—	—	ns
$t_{IH(SD)}$	Input hold time SD default mode	$f_{SDCK} = 24 \text{ MHz}$	0	—	—	ns
CMD, Data outputs referenced to SD_CLK in SD default mode						
$t_{OV(SD)}$	Output valid time SD default mode	$f_{SDCK} = 24 \text{ MHz}$	—	5	7	ns
$t_{OH(SD)}$	Output hold time SD default mode	$f_{SDCK} = 24 \text{ MHz}$	2	—	—	ns
CMD, Data inputs referenced to SD_CLK in SD HS mode						
$t_{ISU(HS)}$	Input setup time SD HS mode	$f_{SDCK} = 48 \text{ MHz}$	2	—	—	ns
$t_{IH(HS)}$	Input hold time SD HS mode	$f_{SDCK} = 48 \text{ MHz}$	0.5	—	—	ns
CMD, Data outputs referenced to SD_CLK in SD HS mode						
$t_{OV(HS)}$	Output valid time SD HS mode	$f_{SDCK} = 48 \text{ MHz}$	—	6.5	8	ns
$t_{OH(HS)}$	Output hold time SD HS mode	$f_{SDCK} = 48 \text{ MHz}$	1.5	—	—	ns

- Note: 1. Guaranteed by characterization results, not tested in production.
 2. I/O driving current is set to 16 mA.
 3. Capacitive load $C = 30 \text{ pF}$, $V_{DD} = 3.3 \text{ V}$ and ambient temperature $T_A = 25 \text{ }^\circ\text{C}$.
 4. Measurement points are set at CMOS levels = $0.5 V_{DD}$.

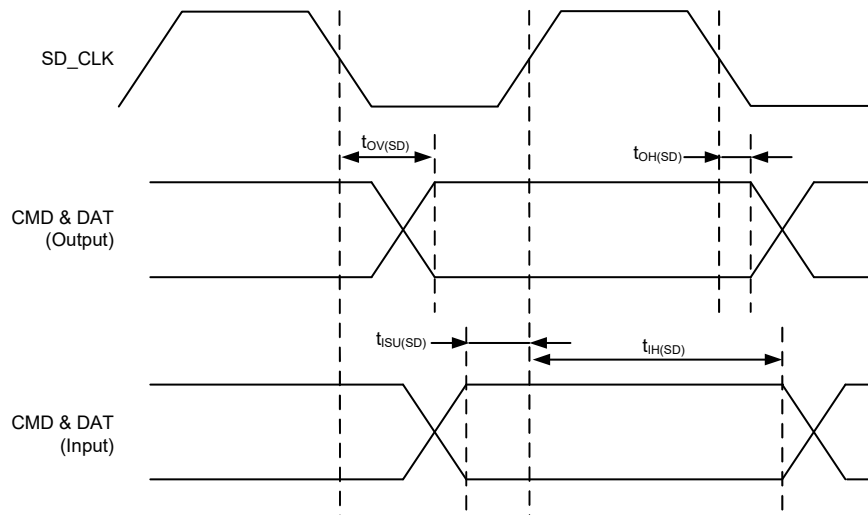

Figure 13. SDIO Default Mode

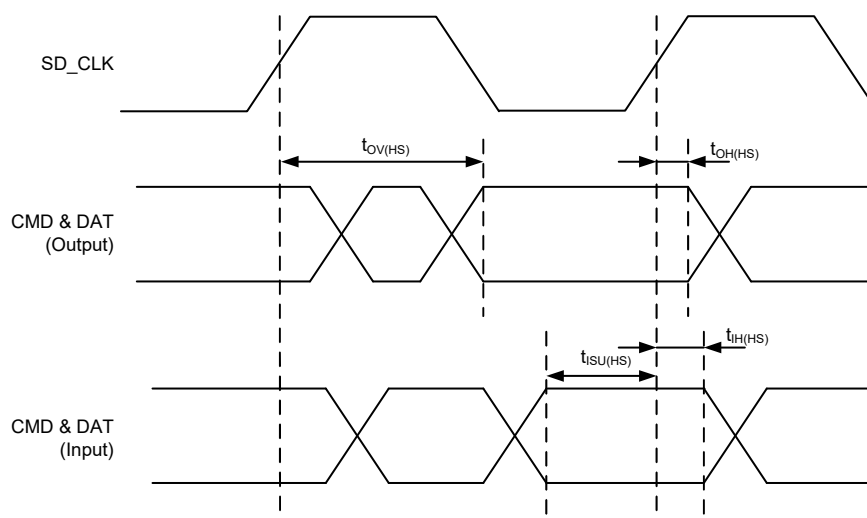

Figure 14. SDIO High-speed Mode

USB Characteristics

The USB interface is USB-IF certified – Full Speed.

Table 26. USB DC Electrical Characteristics

Symbol	Parameter	Conditions	Min.	Typ.	Max.	Unit
V_{DD}	USB operating voltage	—	3.0	—	3.6	V
V_{DI}	Differential input sensitivity	USBDP – USBDM	0.2	—	—	V
V_{CM}	Common mode voltage range	—	0.8	—	2.5	V
V_{SE}	Single-ended receiver threshold	—	0.8	—	2.0	V
V_{OL}	Pad output low voltage	R_L of 1.5 k Ω to V_{DD}	0	—	0.3	V
V_{OH}	Pad output high voltage		2.8	—	3.6	V
V_{CRS}	Differential output signal cross-point voltage		1.3	—	2.0	V
Z_{DRV}	Driver output resistance	—	—	10	—	Ω
C_{IN}	Transceiver pad capacitance	—	—	—	20	pF

- Note: 1. Guaranteed by design, not tested in production.
 2. The USB functionality is ensured down to 2.7 V but not the full USB electrical characteristics which will experience degradation in the 2.7 V to 3.0 V voltage range.
 3. R_L is the internal resistor load connected to the USB driver USBDP.

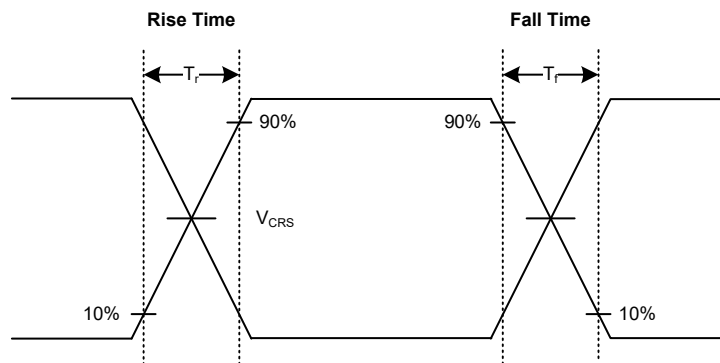

Figure 15. USB Signal Rise Time and Fall Time and Cross-Point Voltage (V_{CRS}) Definition

Table 27. USB AC Electrical Characteristics

Symbol	Parameter	Conditions	Min.	Typ.	Max.	Unit
t_r	Rise time	$C_L = 50 \text{ pF}$	4	—	20	ns
t_f	Fall time	$C_L = 50 \text{ pF}$	4	—	20	ns
$T_{r/f}$	Rise time / fall time matching	$T_{r/f} = t_r / t_f$	90	—	110	%

6 Package Information

Note that the package information provided here is for consultation purposes only. As this information may be updated at regular intervals users are reminded to consult

Additional supplementary information with regard to packaging is listed below. Click on the relevant section to be transferred to the relevant website page.

- [Package Information \(include Outline Dimensions, Product Tape and Reel Specifications\)](#)
- [The Operation Instruction of Packing Materials](#)
- [Carton information](#)

SAW Type 46-pin QFN (6.5mm×4.5mm×0.75mm) Outline Dimensions

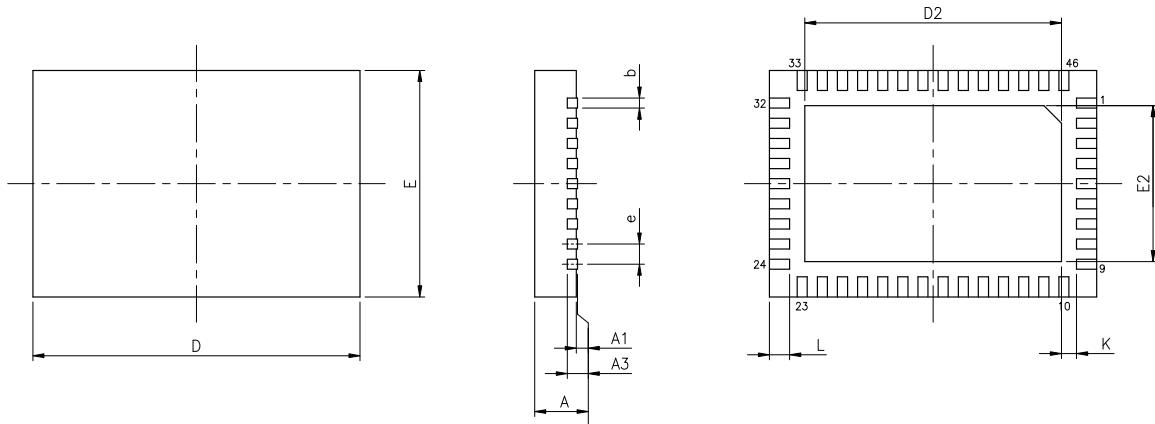

Symbol	Dimensions in inch		
	Min.	Nom.	Max.
A	0.028	0.030	0.031
A1	0.000	0.001	0.002
A3	—	0.008 BSC	—
b	0.006	0.008	0.010
D	—	0.256 BSC	—
E	—	0.177 BSC	—
e	—	0.016 BSC	—
D2	0.199	0.201	0.203
E2	0.120	0.122	0.124
L	0.014	0.016	0.018
K	0.008	—	—

Symbol	Dimensions in mm		
	Min.	Nom.	Max.
A	0.70	0.75	0.80
A1	0.00	0.02	0.05
A3	—	0.203 BSC	—
b	0.15	0.20	0.25
D	—	6.50 BSC	—
E	—	4.50 BSC	—
e	—	0.40 BSC	—
D2	5.05	5.10	5.15
E2	3.05	3.10	3.15
L	0.35	0.40	0.45
K	0.20	—	—

48-pin LQFP (7mm×7mm) Outline Dimensions

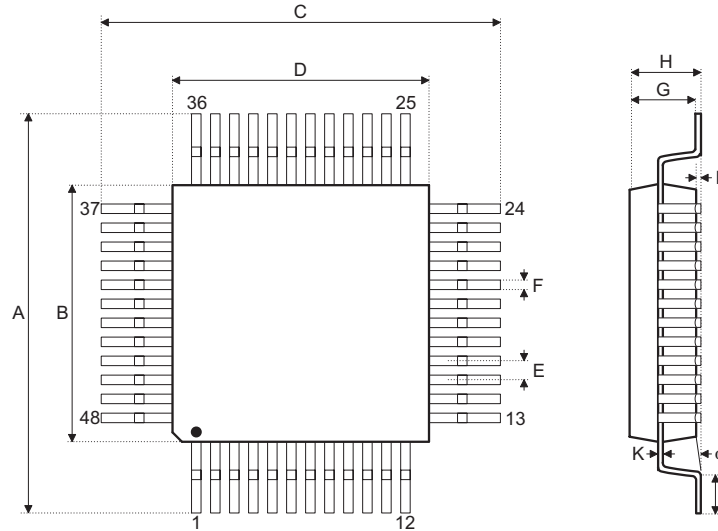

Symbol	Dimensions in inch		
	Min.	Nom.	Max.
A	—	0.354 BSC	—
B	—	0.276 BSC	—
C	—	0.354 BSC	—
D	—	0.276 BSC	—
E	—	0.020 BSC	—
F	0.007	0.009	0.011
G	0.053	0.055	0.057
H	—	—	0.063
I	0.002	—	0.006
J	0.018	0.024	0.030
K	0.004	—	0.008
α	0°	—	7°

Symbol	Dimensions in mm		
	Min.	Nom.	Max.
A	—	9.00 BSC	—
B	—	7.00 BSC	—
C	—	9.00 BSC	—
D	—	7.00 BSC	—
E	—	0.50 BSC	—
F	0.17	0.22	0.27
G	1.35	1.40	1.45
H	—	—	1.60
I	0.05	—	0.15
J	0.45	0.60	0.75
K	0.09	—	0.20
α	0°	—	7°

64-pin LQFP (7mm×7mm) Outline Dimensions

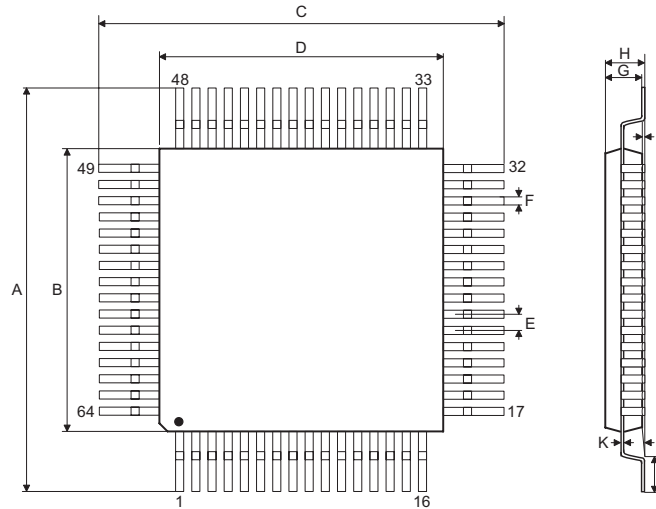

Symbol	Dimensions in inch		
	Min.	Nom.	Max.
A	—	0.354 BSC	—
B	—	0.276 BSC	—
C	—	0.354 BSC	—
D	—	0.276 BSC	—
E	—	0.016 BSC	—
F	0.005	0.007	0.009
G	0.053	0.055	0.057
H	—	—	0.063
I	0.002	—	0.006
J	0.018	0.024	0.030
K	0.004	—	0.008
α	0°	—	7°

Symbol	Dimensions in mm		
	Min.	Nom.	Max.
A	—	9.00 BSC	—
B	—	7.00 BSC	—
C	—	9.00 BSC	—
D	—	7.00 BSC	—
E	—	0.40 BSC	—
F	0.13	0.18	0.23
G	1.35	1.40	1.45
H	—	—	1.60
I	0.05	—	0.15
J	0.45	0.60	0.75
K	0.09	—	0.20
α	0°	—	7°

Copyright© 2020 by HOLTEK SEMICONDUCTOR INC.

The information appearing in this Data Sheet is believed to be accurate at the time of publication. However, Holtek assumes no responsibility arising from the use of the specifications described. The applications mentioned herein are used solely for the purpose of illustration and Holtek makes no warranty or representation that such applications will be suitable without further modification, nor recommends the use of its products for application that may present a risk to human life due to malfunction or otherwise. Holtek's products are not authorized for use as critical components in life support devices or systems. Holtek reserves the right to alter its products without prior notification